

Planning and Optimization

E9. Merge-and-Shrink: Factored Transition Systems

Malte Helmert and Gabriele Röger

Universität Basel

November 16, 2022

Planning and Optimization

November 16, 2022 — E9. Merge-and-Shrink: Factored Transition Systems

E9.1 Motivation

E9.2 Main Idea

E9.3 Atomic Projections

E9.4 Synchronized Product

E9.5 Factored Transition Systems

E9.6 Summary

Content of this Course

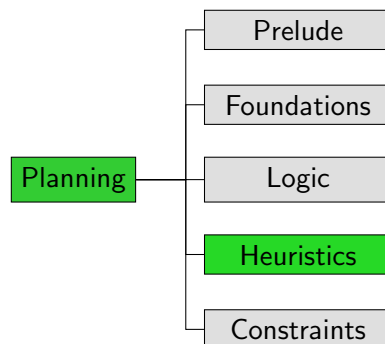

Content of this Course: Heuristics

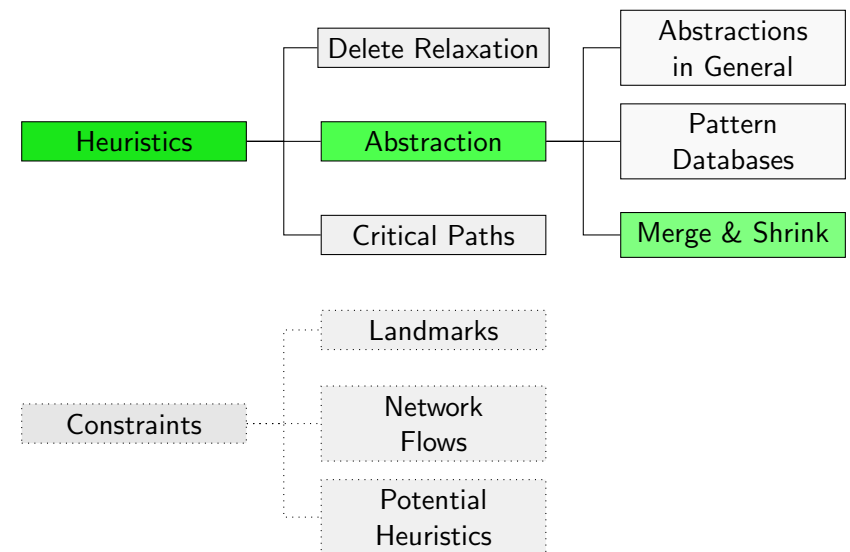

E9.1 Motivation

Beyond Pattern Databases

- ▶ Despite their popularity, pattern databases have some **fundamental limitations** (\rightsquigarrow example on next slides).
- ▶ Today and next time, we study a class of abstractions called **merge-and-shrink abstractions**.
- ▶ Merge-and-shrink abstractions can be seen as a **proper generalization** of pattern databases.
 - ▶ They can do everything that pattern databases can do (modulo polynomial extra effort).
 - ▶ They can do some things that pattern databases cannot.

Back to the Running Example

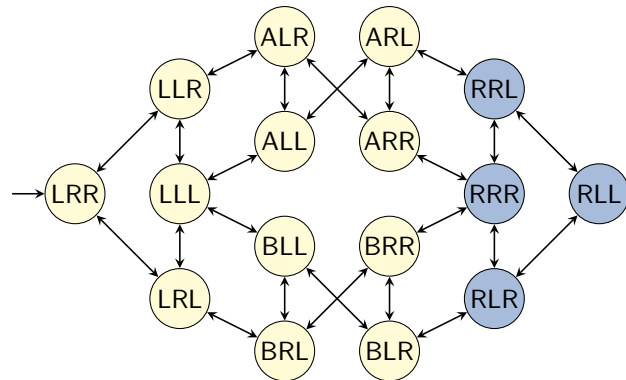

Logistics problem with one package, two trucks, two locations:

- ▶ state variable **package**: $\{L, R, A, B\}$
- ▶ state variable **truck A**: $\{L, R\}$
- ▶ state variable **truck B**: $\{L, R\}$

Example: Projection (1)

$\mathcal{T}^{\pi}_{\{\text{package}\}}$:

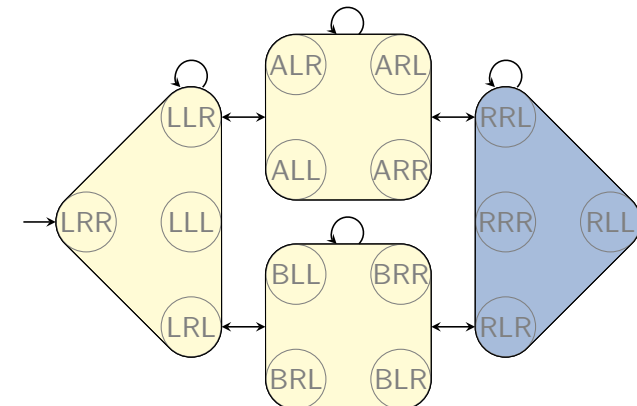

Example: Projection (2)

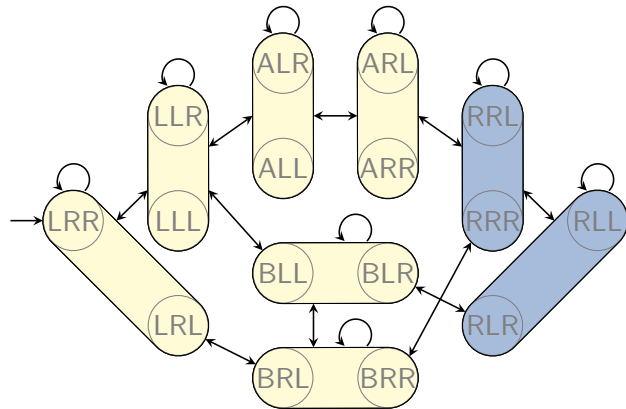
 $\mathcal{T}^{\pi}_{\{\text{package, truck A}\}}:$

Limitations of Projections

How accurate is the PDB heuristic?

- ▶ consider **generalization of the example**:
 N trucks, 1 package
- ▶ consider **any** pattern that is a proper subset of variable set V
- ▶ $h(s_0) \leq 2 \rightsquigarrow$ **no better** than atomic projection to **package**

These values cannot be improved by maximizing over several patterns or using additive patterns.

Merge-and-shrink abstractions can represent heuristics with $h(s_0) \geq 3$ for tasks of this kind of any size.

Time and space requirements are **linear in N** .

(In fact, with time/space $O(N^2)$ we can construct a merge-and-shrink abstraction that gives the **perfect heuristic h^*** for such tasks, but we do not show this here.)

E9.2 Main Idea

Merge-and-Shrink Abstractions: Main Idea

Main Idea of Merge-and-shrink Abstractions

(due to Dräger, Finkbeiner & Podelski, 2006):

Instead of **perfectly** reflecting **a few** state variables, reflect **all** state variables, but in a **potentially lossy** way.

- ▶ Represent planning task as **factored transition system** (FTS): a set of (small) abstract transition systems (**factors**) that jointly represent the full transition system of the task.
- ▶ Iteratively **transform** FTS by:
 - ▶ **merging**: combining two factors into one
 - ▶ **shrinking**: reducing the size of a single factor by abstraction
- ▶ When only a single factor is left, its goal distances are the merge-and-shrink heuristic values.

Merge-and-Shrink Abstractions: Idea

Start from atomic factors (projections to single state variables)

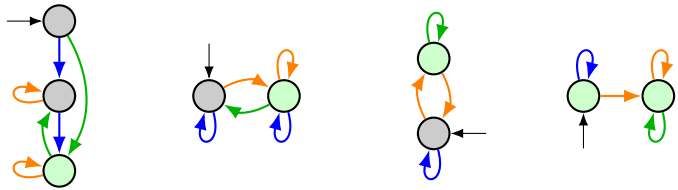

Merge-and-Shrink Abstractions: Idea

Merge: replace two factors with their product

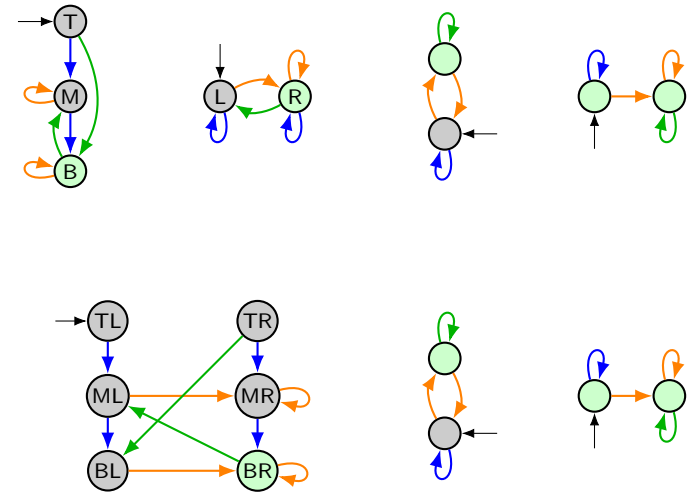

Merge-and-Shrink Abstractions: Idea

Shrink: replace a factor by an abstraction of it

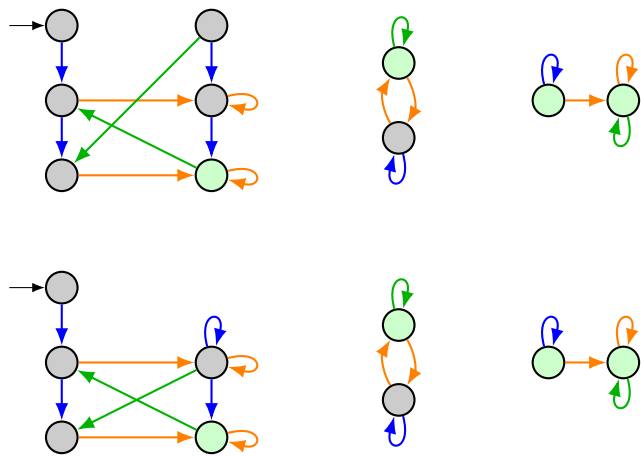

Merge-and-Shrink

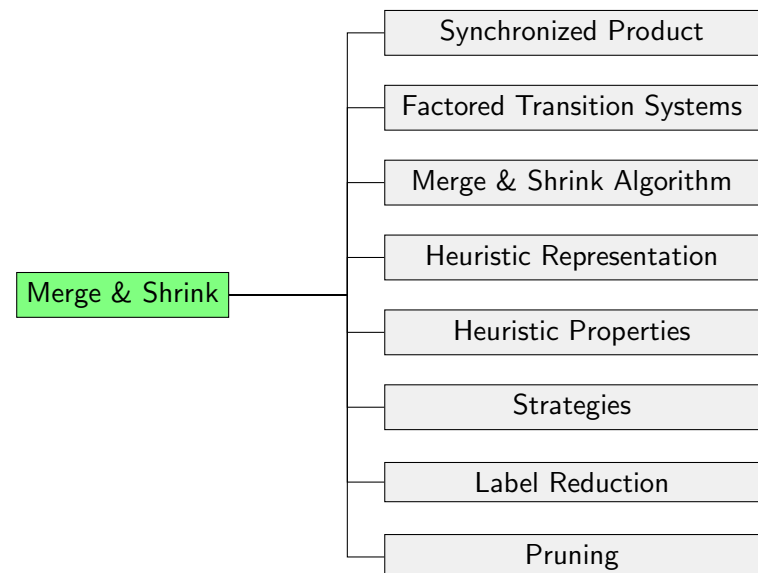

E9.3 Atomic Projections

Running Example: Explanations

- ▶ **Atomic projections** (projections to a single state variable) play an important role for merge-and-shrink abstractions.
- ▶ Unlike previous chapters, **transition labels** are critically important for merge-and-shrink.
- ▶ Hence we now look at the transition systems for atomic projections of our example task, including transition labels.
- ▶ We abbreviate labels (operator names) as in these examples:
 - ▶ **MALR**: move truck **A** from **left** to **right**
 - ▶ **DAR**: drop package from truck **A** at **right** location
 - ▶ **PBL**: pick up package with truck **B** at **left** location
- ▶ We abbreviate parallel arcs with **commas** and **wildcards (*)** as in these examples:
 - ▶ **PAL, DAL**: two parallel arcs labeled **PAL** and **DAL**
 - ▶ **MA****: two parallel arcs labeled **MALR** and **MARL**

Running Example: Atomic Projection for Package

$\mathcal{T}^{\pi}_{\{\text{package}\}}$:

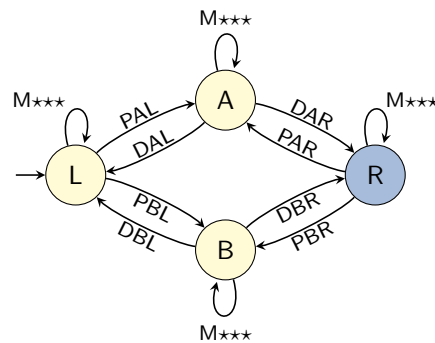

Running Example: Atomic Projection for Truck A

$\mathcal{T}^{\pi}_{\{\text{truck A}\}}$:

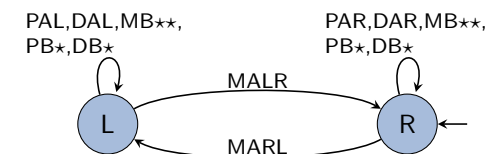

Running Example: Atomic Projection for Truck B

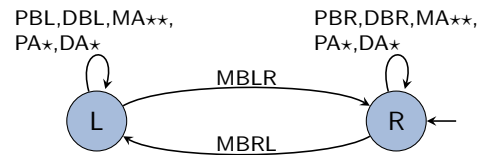
 $\mathcal{T}^{\pi}\{\text{truck B}\}:$

E9.4 Synchronized Product

Merge-and-Shrink

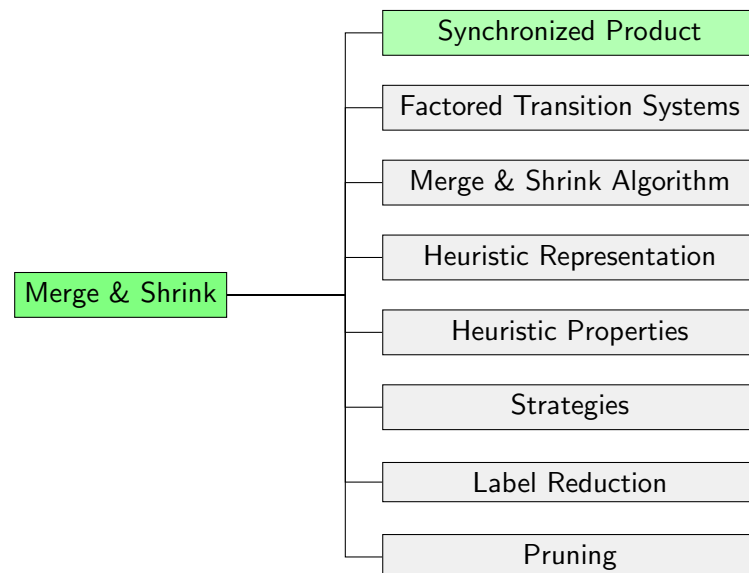

Synchronized Product: Idea

- ▶ Given two abstract transition systems with the same labels, we can compute a **product transition system**.
- ▶ The product transition system **captures all information** of both transition systems.
- ▶ A sequence of labels is a solution for the product iff it is a solution for both factors.

Example: Synchronized Product

$$\mathcal{T}^{\pi}\{\text{package}\} \otimes \mathcal{T}^{\pi}\{\text{truck A}\}:$$

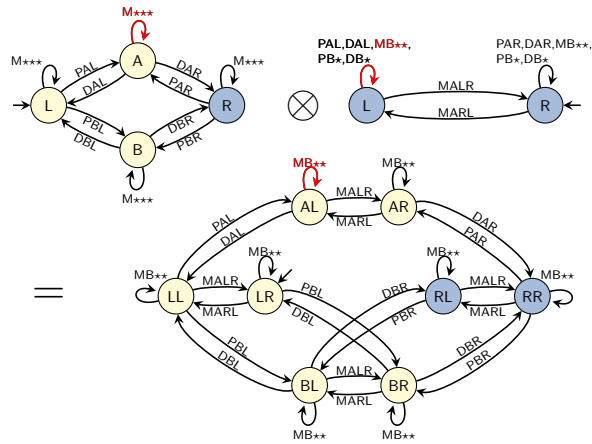
$$T_{\otimes} = \{\langle s_1, s_2 \rangle \xrightarrow{\ell} \langle t_1, t_2 \rangle \mid s_1 \xrightarrow{\ell} t_1 \in T_1 \text{ and } s_2 \xrightarrow{\ell} t_2 \in T_2\}$$

Associativity and Commutativity

- ▶ Up to isomorphism (“names of states”), products are associative and commutative:
 - ▶ $(\mathcal{T} \otimes \mathcal{T}') \otimes \mathcal{T}'' \sim \mathcal{T} \otimes (\mathcal{T}' \otimes \mathcal{T}'')$
 - ▶ $\mathcal{T} \otimes \mathcal{T}' \sim \mathcal{T}' \otimes \mathcal{T}$
- ▶ We do not care about names of states and thus treat products as associative and commutative.
- ▶ We can then define the product of a set $F = \{\mathcal{T}_1, \dots, \mathcal{T}_n\}$ of transition systems: $\bigotimes F := \mathcal{T}_1 \otimes \dots \otimes \mathcal{T}_n$

E9.5 Factored Transition Systems

Merge-and-Shrink

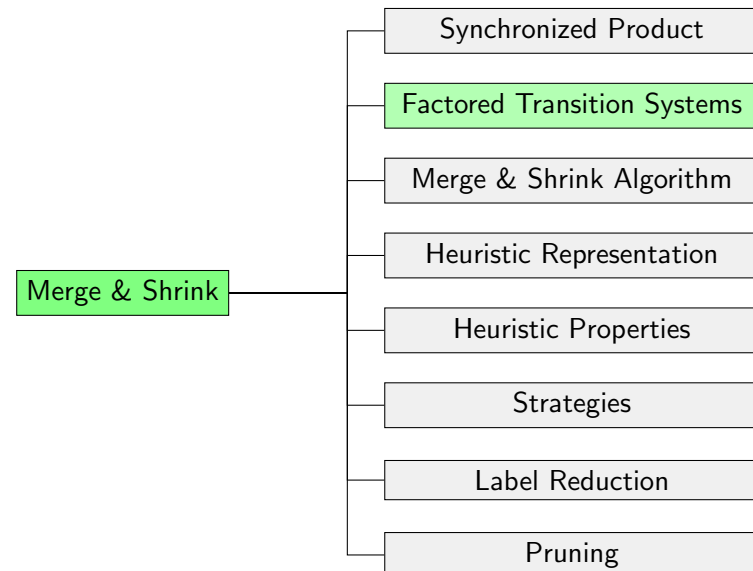

Factored Transition System

Definition (Factored Transition System)

A finite set $F = \{\mathcal{T}_1, \dots, \mathcal{T}_n\}$ of transition systems with the same labels and cost function is called a **factored transition system (FTS)**.

F represents the transition system $\otimes F$.

A planning task gives rise to an FTS via its atomic projections:

Definition (Factored Transition System Induced by Planning Task)

Let Π be a planning task with state variables V .

The **factored transition system induced by Π** is the FTS $F(\Pi) = \{\mathcal{T}^{\pi\{v\}} \mid v \in V\}$.

Back to the Example Product

$$\mathcal{T}^{\pi\{\text{package}\}} \otimes \mathcal{T}^{\pi\{\text{truck A}\}}:$$

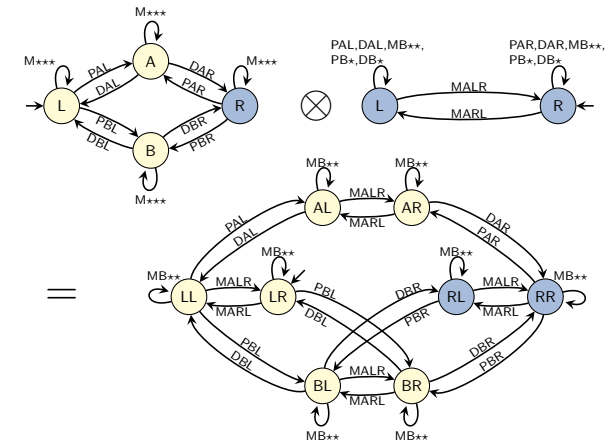

We have $\mathcal{T}^{\pi\{\text{package}\}} \otimes \mathcal{T}^{\pi\{\text{truck A}\}} \sim \mathcal{T}^{\pi\{\text{package, truck A}\}}$. Coincidence?

Products of Projections

Theorem (Products of Projections)

Let Π be a **SAS⁺** planning task with variable set V , and let V_1 and V_2 be **disjoint subsets** of V .

Then $\mathcal{T}^{\pi V_1} \otimes \mathcal{T}^{\pi V_2} \sim \mathcal{T}^{\pi V_1 \cup V_2}$.

\rightsquigarrow products allow us to build finer projections from coarser ones

Products of Projections: Proof (1)

Proof.

Let $\mathcal{T}^{\Pi} = \mathcal{T}(\Pi)$.

Let $\mathcal{T}^1 = \mathcal{T}^{\pi V_1}$, $\mathcal{T}^2 = \mathcal{T}^{\pi V_2}$.

Let $\mathcal{T}^{12} = \mathcal{T}^{\pi V_1 \cup V_2}$.

Let $\mathcal{T}^{\otimes} = \mathcal{T}^1 \otimes \mathcal{T}^2$.

For $x \in \{\Pi, 1, 2, 12, \otimes\}$, let $\mathcal{T}^x = \langle S^x, L, c, T^x, s_0^x, S_*^x \rangle$.

We show $\mathcal{T}^{12} \sim \mathcal{T}^{\otimes}$, i.e., there is a bijection $\sigma : S^{12} \rightarrow S^{\otimes}$ such that for all $s^{12} \in S^{12}$, $t^{12} \in S^{12}$, $l \in L$,

- 1 $s^{12} \xrightarrow{l} t^{12} \in \mathcal{T}^{12}$ iff $\sigma(s^{12}) \xrightarrow{l} \sigma(t^{12}) \in \mathcal{T}^{\otimes}$
- 2 $\sigma(s_0^{12}) = s_0^{\otimes}$
- 3 $s^{12} \in S_*^{12}$ iff $\sigma(s^{12}) \in S_*^{\otimes}$

...

Products of Projections: Proof (2)

Proof (continued).

The states in S^1 are mappings on V_1 .

The states in S^2 are mappings on V_2 .

The states in S^{12} are mappings on $V_1 \cup V_2$.

The states in S^\otimes are pairs $\langle s_1, s_2 \rangle$ where s_i is a mapping on V_i .

\rightsquigarrow The required bijection σ is defined by $\sigma(s_{12}) = \langle s_{12}|_{V_1}, s_{12}|_{V_2} \rangle$, i.e., the pair of projections of s_{12} to V_1 and V_2 .

This is a bijection because V_1 and V_2 are disjoint.

We now need to show properties (1), (2) and (3).

We only show (2) and (3).

The omitted proof of (1) is similar to the proof of (3). ...

Products of Projections: Proof (3)

Proof (continued).

(2): $\sigma(s_0^{12}) = s_0^\otimes$

We have $s_0^{12} = s_0^\Pi|_{V_1 \cup V_2}$ and hence

$$\begin{aligned} \sigma(s_0^{12}) &= \langle (s_0^\Pi|_{V_1 \cup V_2})|_{V_1}, (s_0^\Pi|_{V_1 \cup V_2})|_{V_2} \rangle \\ &= \langle s_0^\Pi|_{V_1}, s_0^\Pi|_{V_2} \rangle \\ &= \langle s_0^1, s_0^2 \rangle \\ &= s_0^\otimes. \end{aligned}$$

...

Products of Projections: Proof (4)

Proof (continued).

(3a): If $s^{12} \in S_\star^{12}$, then $\sigma(s^{12}) \in S_\star^\otimes$

Consider $s^{12} \in S_\star^{12}$.

Then there exists a state $s^\Pi \in S_\star^\Pi$ with $s^{12} = s^\Pi|_{V_1 \cup V_2}$.

We have $\sigma(s^{12}) = \langle s^{12}|_{V_1}, s^{12}|_{V_2} \rangle = \langle s^\Pi|_{V_1}, s^\Pi|_{V_2} \rangle$.

Because s^Π is a goal state of \mathcal{T}^Π ,

$s^\Pi|_{V_1}$ is a goal state of \mathcal{T}^1 and

$s^\Pi|_{V_2}$ is a goal state of \mathcal{T}^2 .

This shows that $\sigma(s^{12}) \in S_\star^1 \times S_\star^2 = S_\star^\otimes$

Products of Projections: Proof (5)

Proof (continued).

(3b): If $s^{12} \notin S_\star^{12}$, then $\sigma(s^{12}) \notin S_\star^\otimes$

Consider $s^{12} \notin S_\star^{12}$.

We have $\sigma(s^{12}) = \langle s^1, s^2 \rangle$ with $s^1 = s^{12}|_{V_1}$ and $s^2 = s^{12}|_{V_2}$.

Because $s^{12} \notin S_\star^{12}$, there is no state $s^\Pi \in S_\star^\Pi$ with $s^{12} = s^\Pi|_{V_1 \cup V_2}$.

Because Π is a SAS⁺ task, this is only possible if s^{12} violates a goal condition of the form $(v = d)$

on some variable $v \in V_1 \cup V_2$.

Without loss of generality, assume that $v \in V_1$.

Then all states $\tilde{s}^\Pi \in S^\Pi$ with $\tilde{s}^\Pi|_{V_1} = s^1$ violate $(v = d)$ and are hence not goal states. This shows $s^1 \notin S_\star^1$ and therefore $\sigma(s^{12}) = \langle s^1, s^2 \rangle \notin S_\star^1 \times S_\star^2 = S_\star^\otimes$. \square

Recovering $\mathcal{T}(\Pi)$ from the Factored Transition System

- ▶ By repeated application of the theorem, we can recover **all pattern database heuristics** of a SAS⁺ planning task as products of atomic factors.
- ▶ Moreover, by computing the product of **all** atomic projections, we can recover the **identity abstraction** $\text{id} = \pi_V$.

This implies:

Corollary (Recovering $\mathcal{T}(\Pi)$ from the Factored Transition System)

Let Π be a SAS⁺ planning task. Then $\otimes F(\Pi) \sim \mathcal{T}(\Pi)$.

This is an important result because it shows that $F(\Pi)$ **represents all important information** about Π .

E9.6 Summary

Summary

- ▶ A **factored transition system** is a set of transition systems that represents a larger transition system by focusing on its individual components (**factors**).
- ▶ For planning tasks, these factors are the **atomic projections** (projections to single state variables).
- ▶ The **synchronized product** $\mathcal{T} \otimes \mathcal{T}'$ of two transition systems with the same labels captures their “joint behaviour”.
- ▶ For SAS⁺ tasks, all **projections** can be obtained as products of atomic projections.
- ▶ In particular, the product of all factors of a SAS⁺ task results in the **full** transition system of the task.