

Planning and Optimization

E6. Optimal Cost Partitioning

Malte Helmert and Gabriele Röger

Universität Basel

Planning and Optimization

— E6. Optimal Cost Partitioning

E6.1 Abstractions

E6.2 Landmarks

E6.3 General Cost Partitioning

E6.4 Summary

Content of this Course

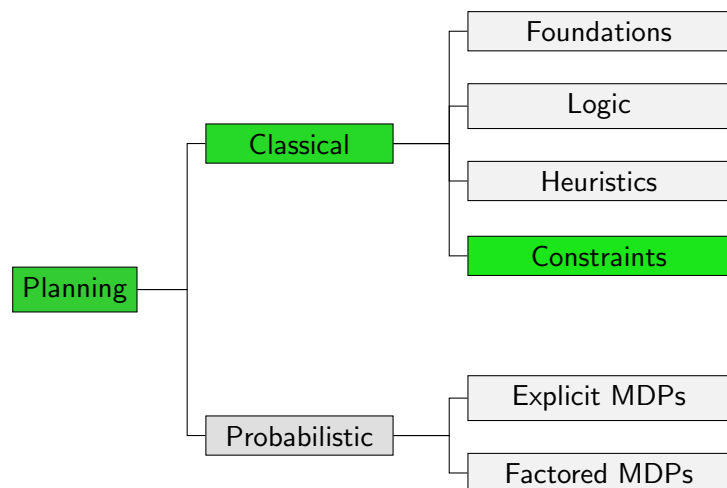

Content of this Course: Constraints

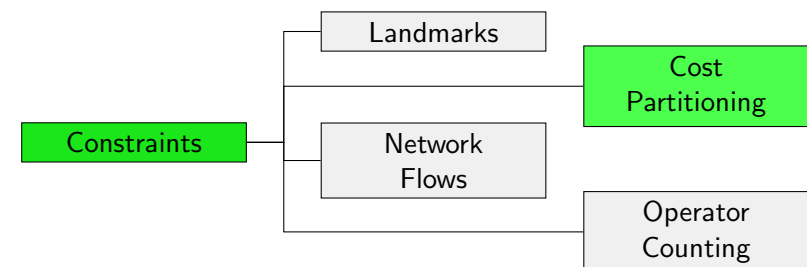

Optimal Cost Partitioning

Optimal Cost Partitioning with LPs

- ▶ Use variables for cost of each operator in each task copy
- ▶ Express heuristic values with linear constraints
- ▶ Maximize sum of heuristic values subject to these constraints

LPs known for

- ▶ abstraction heuristics
- ▶ disjunctive action landmarks

E6.1 Abstractions

LP for Shortest Path in State Space

Variables

Non-negative variable Distance_s for each state s

Objective

Maximize Distance_{s_f}

Subject to

$\text{Distance}_{s_*} = 0$ for all goal states s_*

$\text{Distance}_s \leq \text{Distance}_{s'} + \text{cost}(o)$ for all transitions $s \xrightarrow{o} s'$

Optimal Cost Partitioning for Abstractions I

Variables

For each abstraction α :

Non-negative variable Distance_s^α for each abstract state s ,

Non-negative variable Cost_o^α for each operator o

Objective

Maximize $\sum_\alpha \text{Distance}_{\alpha(s_f)}^\alpha$

...

Optimal Cost Partitioning for Abstractions II

Subject to

$$\sum_{\alpha} \text{Cost}_o^{\alpha} \leq \text{cost}(o) \quad \text{for all operators } o$$

and for all abstractions α

$$\text{Distance}_{s_*}^{\alpha} = 0 \quad \text{for all abstract goal states } s_*$$

$$\text{Distance}_s^{\alpha} \leq \text{Distance}_{s'}^{\alpha} + \text{Cost}_o^{\alpha} \quad \text{for all transition } s \xrightarrow{o} s'$$

Example (1)

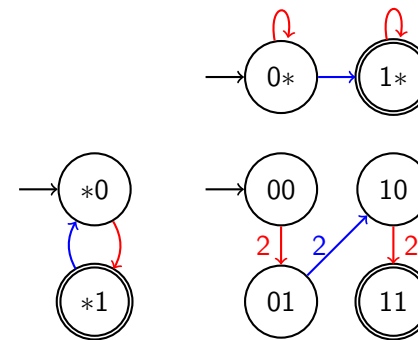

Example (2)

Maximize $\text{Distance}_0^1 + \text{Distance}_0^2$ subject to

$$\text{Cost}_{\text{red}}^1 + \text{Cost}_{\text{red}}^2 \leq 2$$

$$\text{Cost}_{\text{blue}}^1 + \text{Cost}_{\text{blue}}^2 \leq 2$$

$$\text{Distance}_1^1 = 0$$

$$\text{Distance}_0^1 \leq \text{Distance}_0^1 + \text{Cost}_{\text{red}}^1$$

$$\text{Distance}_0^1 \leq \text{Distance}_1^1 + \text{Cost}_{\text{blue}}^1$$

$$\text{Distance}_1^1 \leq \text{Distance}_1^1 + \text{Cost}_{\text{red}}^1$$

$$\text{Distance}_1^2 = 0$$

$$\text{Distance}_0^2 \leq \text{Distance}_1^2 + \text{Cost}_{\text{red}}^2$$

$$\text{Distance}_1^2 \leq \text{Distance}_0^2 + \text{Cost}_{\text{blue}}^2$$

$$\text{Distance}_s^{\alpha} \geq 0 \quad \text{for } \alpha \in \{1, 2\}, s \in \{0, 1\}$$

$$\text{Cost}_o^{\alpha} \geq 0 \quad \text{for } \alpha \in \{1, 2\}, o \in \{\text{red}, \text{blue}\}$$

Caution

A word of warning

- ▶ optimization for every state gives **best-possible** cost partitioning
- ▶ but **takes time**

Better heuristic guidance often does not outweigh the overhead.

E6.2 Landmarks

Optimal Cost Partitioning for Landmarks

- ▶ Use again LP that covers heuristic computation and cost partitioning.
- ▶ LP variable $Cost_L$ for cost of landmark L in induced task
- ▶ Explicit variables for cost partitioning not necessary. Use implicitly $cost_L(o) = Cost_L$ for all $o \in L$ and 0 otherwise.

Optimal Cost Partitioning for Landmarks: LP

Variables

Non-negative variable $Cost_L$ for each disj. action landmark $L \in \mathcal{L}$

Objective

Maximize $\sum_{L \in \mathcal{L}} Cost_L$

Subject to

$$\sum_{L \in \mathcal{L}: o \in L} Cost_L \leq cost(o) \quad \text{for all operators } o$$

Example (1)

Example

Let Π be a planning task with operators o_1, \dots, o_4 and $cost(o_1) = 3, cost(o_2) = 4, cost(o_3) = 5$ and $cost(o_4) = 0$.

Let the following be disjunctive action landmarks for Π :

$$\mathcal{L}_1 = \{o_4\}$$

$$\mathcal{L}_2 = \{o_1, o_2\}$$

$$\mathcal{L}_3 = \{o_1, o_3\}$$

$$\mathcal{L}_4 = \{o_2, o_3\}$$

Example (2)

Example

Maximize $Cost_{\mathcal{L}_1} + Cost_{\mathcal{L}_2} + Cost_{\mathcal{L}_3} + Cost_{\mathcal{L}_4}$ subject to

$$[o_1] \quad Cost_{\mathcal{L}_2} + Cost_{\mathcal{L}_3} \leq 3$$

$$[o_2] \quad Cost_{\mathcal{L}_2} + Cost_{\mathcal{L}_4} \leq 4$$

$$[o_3] \quad Cost_{\mathcal{L}_3} + Cost_{\mathcal{L}_4} \leq 5$$

$$[o_4] \quad Cost_{\mathcal{L}_1} \leq 0$$

$$Cost_{\mathcal{L}_i} \geq 0 \quad \text{for } i \in \{1, 2, 3, 4\}$$

Optimal Cost Partitioning for Landmarks (Dual view)

Variables

Non-negative variable $Applied_o$ for each operator o

Objective

Minimize $\sum_o Applied_o \cdot cost(o)$

Subject to

$$\sum_{o \in L} Applied_o \geq 1 \quad \text{for all landmarks } L$$

Minimize “plan cost” with all landmarks satisfied.

Example: Dual View

Example (Optimal Cost Partitioning: Dual View)

Minimize $3Applied_{o_1} + 4Applied_{o_2} + 5Applied_{o_3}$ subject to

$$Applied_{o_4} \geq 1$$

$$Applied_{o_1} + Applied_{o_2} \geq 1$$

$$Applied_{o_1} + Applied_{o_3} \geq 1$$

$$Applied_{o_2} + Applied_{o_3} \geq 1$$

$$Applied_{o_i} \geq 0 \quad \text{for } i \in \{1, 2, 3, 4\}$$

This is equal to the LP relaxation of the MHS heuristic.

E6.3 General Cost Partitioning

General Cost Partitioning

Cost functions are **usually non-negative**

- ▶ We tacitly also required this for task copies
- ▶ Makes intuitively sense: original costs are non-negative
- ▶ But: not necessary for cost-partitioning!

General Cost Partitioning

Definition (General Cost Partitioning)

Let Π be a planning task with operators O .

A **general cost partitioning** for Π is a tuple $\langle cost_1, \dots, cost_n \rangle$, where

- ▶ $cost_i : O \rightarrow \mathbb{R}$ for $1 \leq i \leq n$ and
- ▶ $\sum_{i=1}^n cost_i(o) \leq cost(o)$ for all $o \in O$.

General Cost Partitioning: Admissibility

Theorem (Sum of Solution Costs is Admissible)

Let Π be a planning task, $\langle cost_1, \dots, cost_n \rangle$ be a **general cost partitioning** and $\langle \Pi_1, \dots, \Pi_n \rangle$ be the tuple of induced tasks.

Then the sum of the solution costs of the induced tasks is an **admissible heuristic** for Π , i.e., $\sum_{i=1}^n h_{\Pi_i}^* \leq h_{\Pi}^*$.

(Proof omitted.)

General Cost Partitioning: Example

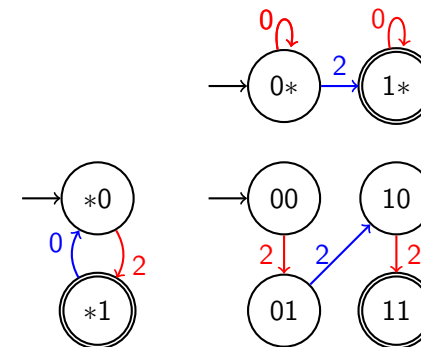

Heuristic value: $2 + 2 = 4$

General Cost Partitioning: Example

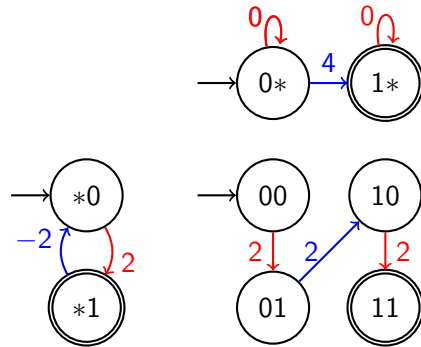

Heuristic value: $4 + 2 = 6$

General Cost Partitioning: Example

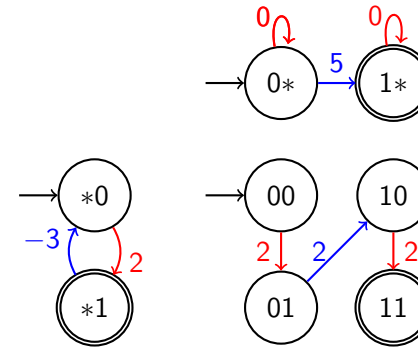

Heuristic value: $-\infty + 5 = -\infty$

LP for Shortest Path in State Space with Negative Costs

Variables

General variable $Distance_s$ for each state s

Objective

Maximize $Distance_{s_f}$

Subject to

$Distance_{s_*} \leq 0$ for all goal states s_*

$Distance_s \leq Distance_{s'} + cost(o)$ for all **alive** transitions $s \xrightarrow{o} s'$

alive: on any path from initial state to goal state

Modifications also correct (but unnecessary) for non-negative costs

E6.4 Summary

Summary

- ▶ For abstraction heuristics and disjunctive action landmarks, we know how to determine an **optimal cost partitioning**, using linear programming.
- ▶ Although solving a linear program is possible in polynomial time, the better heuristic guidance often does not outweigh the overhead.
- ▶ In contrast to standard (non-negative) cost partitioning, **general cost partitioning** allows negative operators costs.
- ▶ General cost partitioning has the same relevant properties as non-negative cost partitioning but is more powerful.