

Planning and Optimization

D4. Pattern Databases: Introduction

Malte Helmert and Gabriele Röger

Universität Basel

Content of this Course

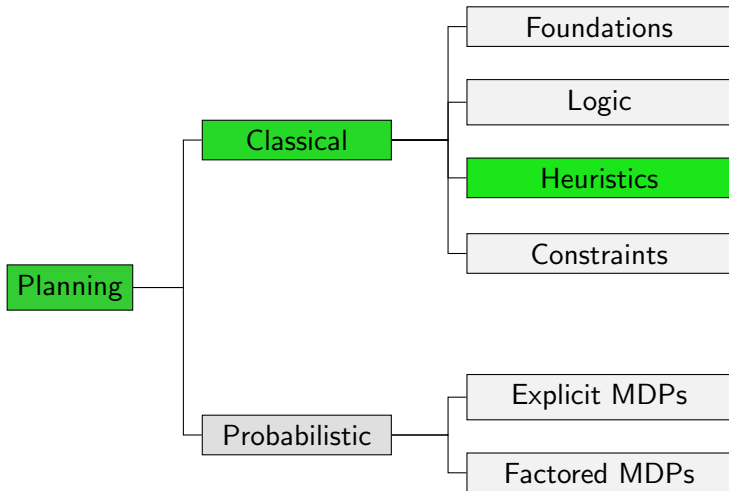

Content of this Course: Heuristics

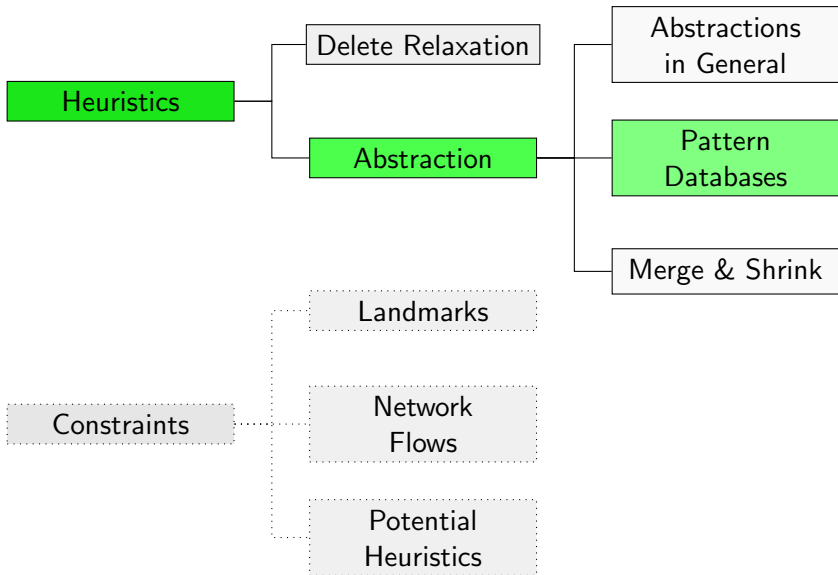

Projections and Pattern Database Heuristics

Pattern Database Heuristics

- The most commonly used abstraction heuristics in search and planning are **pattern database (PDB) heuristics**.
- PDB heuristics were originally introduced for the **15-puzzle** (Culberson & Schaeffer, 1996) and for **Rubik's cube** (Korf, 1997).
- The first use for **domain-independent planning** is due to Edelkamp (2001).
- Since then, much research has focused on the theoretical properties of pattern databases, how to use pattern databases more effectively, how to find good patterns, etc.
- Pattern databases are a **very active research area** both in planning and in (domain-specific) heuristic search.
- For many search problems, pattern databases are the **most effective admissible heuristics** currently known.

Pattern Database Heuristics Informally

Pattern Databases: Informally

A pattern database heuristic for a planning task is an abstraction heuristic where

- some aspects of the task are represented in the abstraction **with perfect precision**, while
- all other aspects of the task are **not represented at all**.

This is achieved by **projecting** the task onto the variables that describe the aspects that are represented.

Example (15-Puzzle)

- Choose a subset T of tiles (the **pattern**).
- Faithfully represent the locations of T in the abstraction.
- Assume that all other tiles and the blank can be anywhere in the abstraction.

Projections

Formally, pattern database heuristics are abstraction heuristics induced by a particular class of abstractions called **projections**.

Definition (Projection)

Let Π be an FDR planning task with variables V and states S . Let $P \subseteq V$, and let S' be the set of states over P .

The **projection** $\pi_P : S \rightarrow S'$ is defined as $\pi_P(s) := s|_P$, (where $s|_P(v) := s(v)$ for all $v \in P$).

We call P the **pattern** of the projection π_P .

In other words, π_P maps two states s_1 and s_2 to the same abstract state iff they agree on all variables in P .

Pattern Database Heuristics

Abstraction heuristics based on projections are called **pattern database (PDB)** heuristics.

Definition (Pattern Database Heuristic)

The abstraction heuristic induced by π_P is called a **pattern database heuristic** or **PDB heuristic**.

We write h^P as a shorthand for h^{π_P} .

Why are they called **pattern database heuristics**?

- Heuristic values for PDB heuristics are traditionally stored in a 1-dimensional table (array) called a **pattern database (PDB)**. Hence the name “PDB heuristic”.
- The word **pattern database** alludes to **endgame databases** for 2-player games (in particular chess and checkers).

Example: Transition System

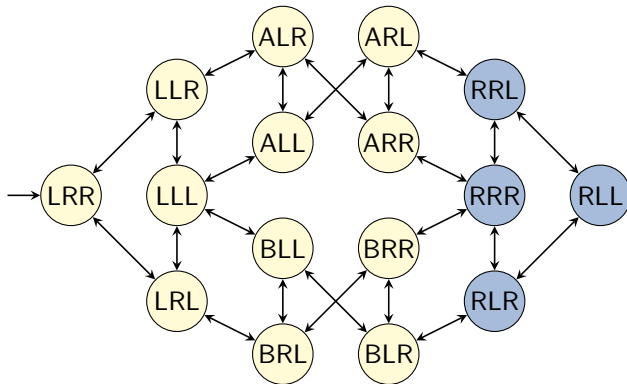

Logistics problem with one package, two trucks, two locations:

- state variable **package**: $\{L, R, A, B\}$
- state variable **truck A**: $\{L, R\}$
- state variable **truck B**: $\{L, R\}$

Example: Projection (1)

Abstraction induced by $\pi_{\{\text{package}\}}$:

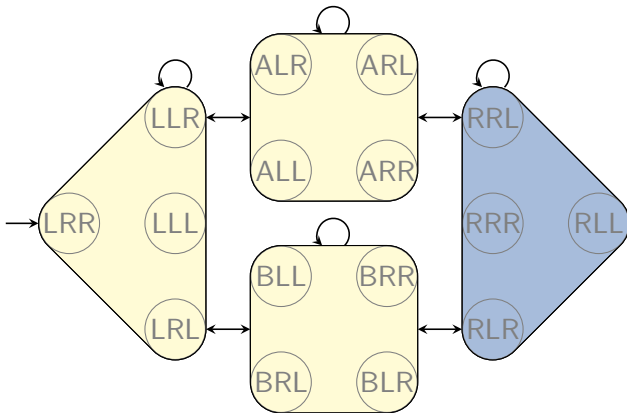

$$h^{\{\text{package}\}}(\text{LRR}) = 2$$

Example: Projection (2)

Abstraction induced by $\pi_{\{\text{package, truck A}\}}$:

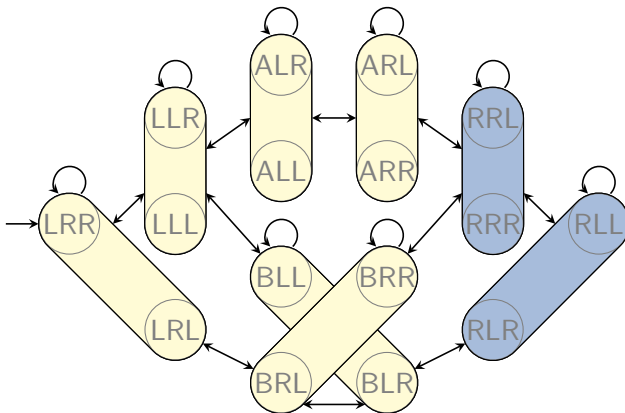

$$h_{\{\text{package, truck A}\}}(\text{LRR}) = 2$$

Example: Projection (2)

Abstraction induced by $\pi_{\{\text{package, truck A}\}}$:

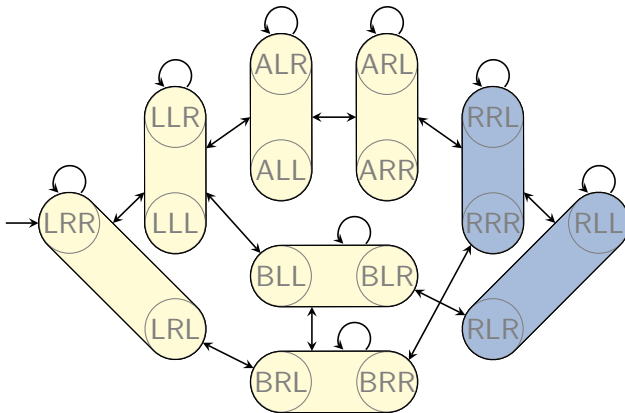

$$h_{\{\text{package, truck A}\}}(\text{LRR}) = 2$$

Pattern Databases: Chapter Overview

In the following, we will discuss:

- how to **implement** PDB heuristics
 ↪ this chapter
- how to effectively make use of **multiple** PDB heuristics
 ↪ Chapter D5
- how to **find good patterns** for PDB heuristics
 ↪ Chapter D6

Implementing PDBs: Precomputation

Pattern Database Implementation

Assume we are given a pattern P for a planning task Π .
How do we implement h^P ?

- 1 In a **precomputation** step, we compute a graph representation for the abstraction $\mathcal{T}(\Pi)^{\pi_P}$ and compute the abstract goal distance for each abstract state.
- 2 During search, we use the precomputed abstract goal distances in a **lookup** step.

Precomputation Step

Let Π be a planning task and P a pattern.

Let $\mathcal{T} = \mathcal{T}(\Pi)$ and $\mathcal{T}' = \mathcal{T}^{\pi_P}$.

- We want to compute a graph representation of \mathcal{T}' .
- \mathcal{T}' is defined through an abstraction of \mathcal{T} .
 - For example, each concrete transition induces an abstract transition.
- However, we cannot **compute** \mathcal{T}' by iterating over all transitions of \mathcal{T} .
 - This would take time $\Omega(\|\mathcal{T}\|)$.
 - This is prohibitively long (or else we could solve the task using uniform-cost search or similar techniques).
- Hence, we need a way of computing \mathcal{T}' in time which is **polynomial only in $\|\Pi\|$ and $\|\mathcal{T}'\|$** .

Syntactic Projections

Definition (Syntactic Projection)

Let $\Pi = \langle V, I, O, \gamma \rangle$ be an FDR planning task, and let $P \subseteq V$ be a subset of its variables.

The **syntactic projection** $\Pi|_P$ of Π to P is the FDR planning task $\langle P, I|_P, \{o|_P \mid o \in O\}, \gamma|_P \rangle$, where

- $\varphi|_P$ for formula φ is defined as the formula obtained from φ by replacing all atoms $(v = d)$ with $v \notin P$ by \top , and
- $o|_P$ for operator o is defined by replacing all formulas φ occurring in the precondition or effect conditions of o with $\varphi|_P$ and all atomic effects $(v := d)$ with $v \notin P$ with the empty effect \top .

Put simply, $\Pi|_P$ throws away all information not pertaining to variables in P .

Equivalence Theorem for Syntactic Projections

Theorem (Syntactic Projections vs. Projections)

Let Π be a SAS⁺ task, and let P be a pattern for Π .

Then $\mathcal{T}(\Pi|_P) \stackrel{\mathcal{G}}{\sim} \mathcal{T}(\Pi)^{\pi_P}$.

Proof.

\rightsquigarrow exercises



PDB Computation

Using the equivalence theorem, we can compute pattern databases for SAS⁺ tasks Π and patterns P :

Computing Pattern Databases

def compute-PDB(Π , P):

 Compute $\Pi' := \Pi|_P$.

 Compute $\mathcal{T}' := \mathcal{T}(\Pi')$.

 Perform a backward uniform-cost search from the goal states of \mathcal{T}' to compute all abstract goal distances.

PDB := a table containing all goal distances in \mathcal{T}'

return *PDB*

The algorithm runs **in polynomial time and space** in terms of $\|\Pi\| + |PDB|$.

Generalizations of the Equivalence Theorem

- The restriction to SAS^+ tasks is necessary.
- We can slightly generalize the result if we allow general negation-free formulas, but still forbid conditional effects.
 - In that case, the weighted graph of $\mathcal{T}(\Pi)^{\pi_P}$ is isomorphic to a subgraph of the weighted graph of $\mathcal{T}(\Pi|_P)$.
 - This means that we can use $\mathcal{T}(\Pi|_P)$ to derive an admissible estimate of h^P .
- With negations in conditions or with conditional effects, not even this weaker result holds.

Going Beyond SAS⁺ Tasks

- Most practical implementations of PDB heuristics are limited to SAS⁺ tasks (or modest generalizations).
 - One way to avoid the issues with general FDR tasks is to convert them to equivalent SAS⁺ tasks.
 - However, most direct conversions can exponentially increase the task size in the worst case.
- ↪ We will only consider SAS⁺ tasks in the chapters dealing with pattern databases.

Implementing PDBs: Lookup

Lookup Step: Overview

- During search, the PDB is the only piece of information necessary to represent h^P . (It is not necessary to store the abstract transition system itself at this point.)
- Hence, the space requirements for PDBs during search are linear in the number of abstract states S' : there is one table entry for each abstract state.
- During search, $h^P(s)$ is computed by mapping $\pi_P(s)$ to a natural number in the range $\{0, \dots, |S'| - 1\}$ using a **perfect hash function**, then looking up the table entry for this number.

Lookup Step: Algorithm

Let $P = \{v_1, \dots, v_k\}$ be the pattern.

- We assume that all variable domains are natural numbers counted from 0, i.e., $\text{dom}(v) = \{0, 1, \dots, |\text{dom}(v)| - 1\}$.
- For all $i \in \{1, \dots, k\}$, we precompute $N_i := \prod_{j=1}^{i-1} |\text{dom}(v_j)|$.

Then we can look up heuristic values as follows:

Computing Pattern Database Heuristics

```
def PDB-heuristic(s):  
    index :=  $\sum_{i=1}^k N_i s(v_i)$   
    return PDB[index]
```

- This is a **very fast** operation: it can be performed in $O(k)$.
- For comparison, most relaxation heuristics need time $O(\|\Pi\|)$ per state.

Lookup Step: Example (1)

Abstraction induced by $\pi_{\{\text{package}, \text{truck A}\}}$:

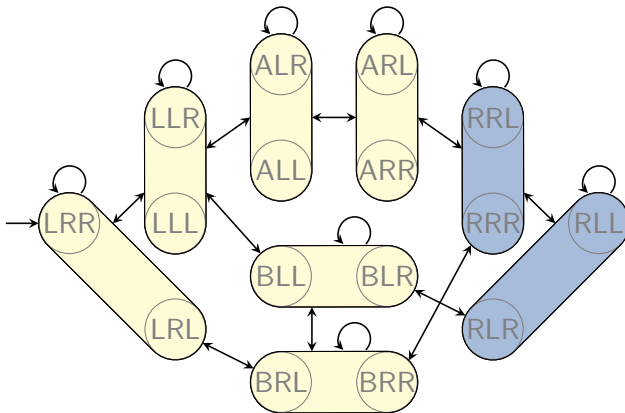

Lookup Step: Example (2)

- $P = \{v_1, v_2\}$ with $v_1 = \text{package}$, $v_2 = \text{truck A}$.
- $\text{dom}(v_1) = \{L, R, A, B\} \approx \{0, 1, 2, 3\}$
- $\text{dom}(v_2) = \{L, R\} \approx \{0, 1\}$

$$\rightsquigarrow N_1 = \prod_{j=1}^0 |\text{dom}(v_j)| = 1, N_2 = \prod_{j=1}^1 |\text{dom}(v_j)| = 4$$

$$\rightsquigarrow \text{index}(s) = 1 \cdot s(\text{package}) + 4 \cdot s(\text{truck A})$$

Pattern database:

abstract state	LL	RL	AL	BL	LR	RR	AR	BR
index	0	1	2	3	4	5	6	7
value	2	0	2	1	2	0	1	1

Summary

Summary

- **Pattern database (PDB) heuristics** are abstraction heuristics based on **projection** to a subset of variables.
- For SAS⁺ tasks, they can easily be implemented via **syntactic projections** of the task representation.
- PDBs are **lookup tables** that store heuristic values, indexed by **perfect hash values** for projected states.
- PDB values can be looked up **very fast**, in time $O(k)$ for a projection to k variables.