

# Planning and Optimization

## D3. Abstractions: Additive Abstractions

Malte Helmert and Gabriele Röger

Universität Basel

November 3, 2020

# Planning and Optimization

November 3, 2020 — D3. Abstractions: Additive Abstractions

D3.1 Additivity

D3.2 Outlook

D3.3 Summary

## Content of this Course

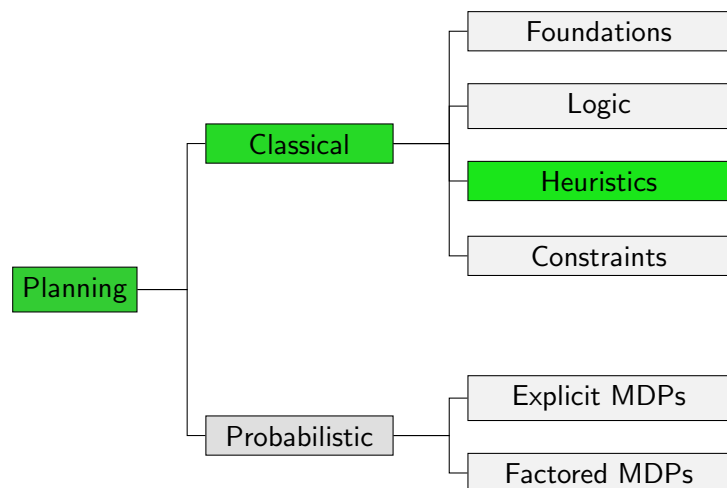

## Content of this Course: Heuristics

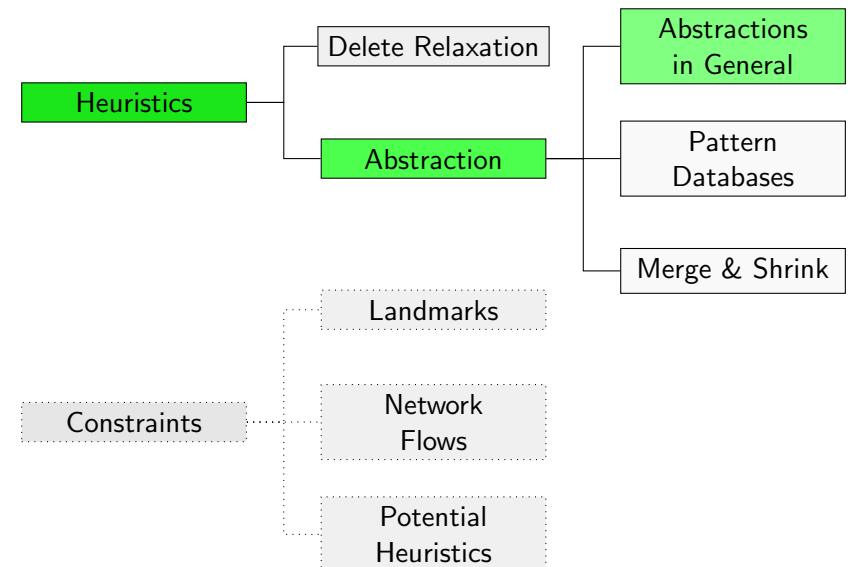

## D3.1 Additivity

## Orthogonality of Abstractions

### Definition (Orthogonal)

Let  $\alpha_1$  and  $\alpha_2$  be abstractions of transition system  $\mathcal{T}$ .

We say that  $\alpha_1$  and  $\alpha_2$  are **orthogonal** if for all transitions  $s \xrightarrow{\ell} t$  of  $\mathcal{T}$ , we have  $\alpha_i(s) = \alpha_i(t)$  for at least one  $i \in \{1, 2\}$ .

## Affecting Transition Labels

### Definition (Affecting Transition Labels)

Let  $\mathcal{T}$  be a transition system, and let  $\ell$  be one of its labels.

We say that  $\ell$  **affects**  $\mathcal{T}$  if  $\mathcal{T}$  has a transition  $s \xrightarrow{\ell} t$  with  $s \neq t$ .

### Theorem (Affecting Labels vs. Orthogonality)

Let  $\alpha_1$  and  $\alpha_2$  be abstractions of transition system  $\mathcal{T}$ .

If no label of  $\mathcal{T}$  affects both  $\mathcal{T}^{\alpha_1}$  and  $\mathcal{T}^{\alpha_2}$ ,  
then  $\alpha_1$  and  $\alpha_2$  are orthogonal.

(Easy proof omitted.)

## Orthogonal Abstractions: Example

	2		6
5	7		
3	4	1	

9		12	
		14	13
			11
15	10	8	

Are the abstractions orthogonal?

## Orthogonal Abstractions: Example

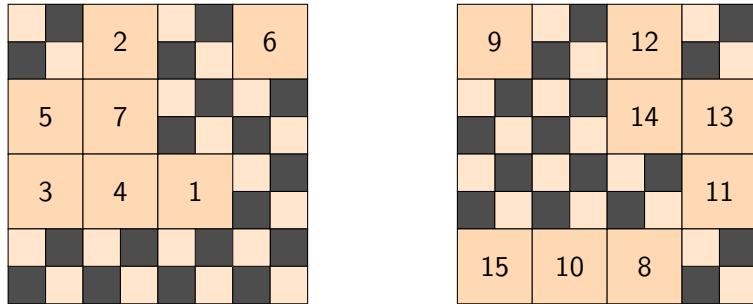

Are the abstractions orthogonal?

## Orthogonality and Additivity

### Theorem (Additivity for Orthogonal Abstractions)

Let  $h^{\alpha_1}, \dots, h^{\alpha_n}$  be abstraction heuristics of the same transition system such that  $\alpha_i$  and  $\alpha_j$  are orthogonal for all  $i \neq j$ .

Then  $\sum_{i=1}^n h^{\alpha_i}$  is a safe, goal-aware, admissible and consistent heuristic for  $\Pi$ .

## Orthogonality and Additivity: Example

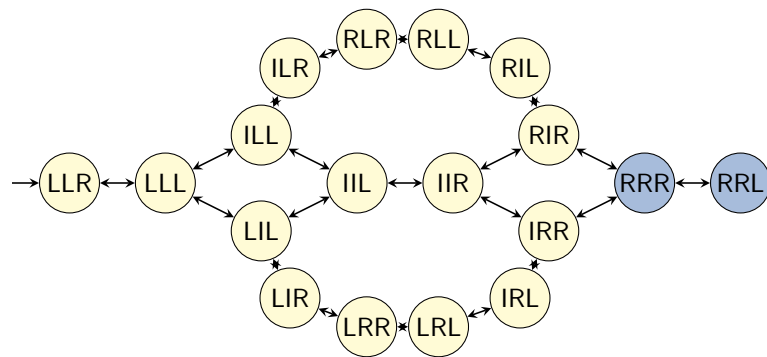

transition system  $\mathcal{T}$

state variables: first package, second package, truck

## Orthogonality and Additivity: Example

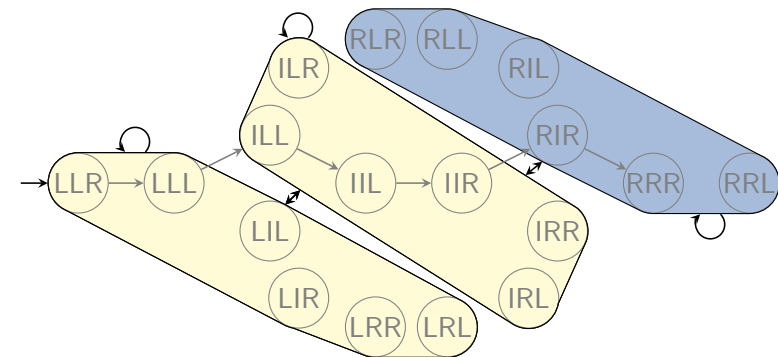

abstraction  $\alpha_1$

abstraction: only consider value of first package

## Orthogonality and Additivity: Example

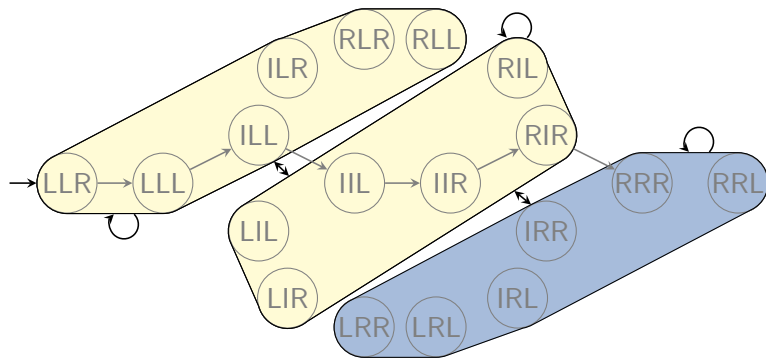

abstraction  $\alpha_2$  (orthogonal to  $\alpha_1$ )  
 abstraction: only consider value of second package

## Orthogonality and Additivity: Proof (1)

**Proof.**

We prove goal-awareness and consistency;  
 the other properties follow from these two.

Let  $\mathcal{T} = \langle S, L, c, T, s_0, S_* \rangle$  be the concrete transition system.

Let  $h = \sum_{i=1}^n h^{\alpha_i}$ .

**Goal-awareness:** For goal states  $s \in S_*$ ,

$h(s) = \sum_{i=1}^n h^{\alpha_i}(s) = \sum_{i=1}^n 0 = 0$  because all individual  
 abstraction heuristics are goal-aware. ...

## Orthogonality and Additivity: Proof (2)

**Proof (continued).**

**Consistency:** Let  $s \xrightarrow{o} t \in T$ . We must prove  $h(s) \leq c(o) + h(t)$ .

Because the abstractions are orthogonal,  $\alpha_i(s) \neq \alpha_i(t)$   
 for **at most one**  $i \in \{1, \dots, n\}$ .

**Case 1:**  $\alpha_i(s) = \alpha_i(t)$  for all  $i \in \{1, \dots, n\}$ .

$$\begin{aligned} \text{Then } h(s) &= \sum_{i=1}^n h^{\alpha_i}(s) \\ &= \sum_{i=1}^n h_{\mathcal{T}\alpha_i}^*(\alpha_i(s)) \\ &= \sum_{i=1}^n h_{\mathcal{T}\alpha_i}^*(\alpha_i(t)) \\ &= \sum_{i=1}^n h^{\alpha_i}(t) \\ &= h(t) \leq c(o) + h(t). \end{aligned}$$

...

## Orthogonality and Additivity: Proof (3)

**Proof (continued).**

**Case 2:**  $\alpha_i(s) \neq \alpha_i(t)$  for exactly one  $i \in \{1, \dots, n\}$ .

Let  $k \in \{1, \dots, n\}$  such that  $\alpha_k(s) \neq \alpha_k(t)$ .

$$\begin{aligned} \text{Then } h(s) &= \sum_{i=1}^n h^{\alpha_i}(s) \\ &= \sum_{i \in \{1, \dots, n\} \setminus \{k\}} h_{\mathcal{T}\alpha_i}^*(\alpha_i(s)) + h^{\alpha_k}(s) \\ &\leq \sum_{i \in \{1, \dots, n\} \setminus \{k\}} h_{\mathcal{T}\alpha_i}^*(\alpha_i(t)) + c(o) + h^{\alpha_k}(t) \\ &= c(o) + \sum_{i=1}^n h^{\alpha_i}(t) \\ &= c(o) + h(t), \end{aligned}$$

where the inequality holds because  $\alpha_i(s) = \alpha_i(t)$  for all  $i \neq k$   
 and  $h^{\alpha_k}$  is consistent.  $\square$

## D3.2 Outlook

## Using Abstraction Heuristics in Practice

In practice, there are conflicting goals for abstractions:

- ▶ we want to obtain an **informative heuristic**, but
- ▶ want to keep its **representation small**.

Abstractions have small representations if

- ▶ there are **few abstract states** and
- ▶ there is a **succinct encoding for  $\alpha$** .

## Counterexample: One-State Abstraction

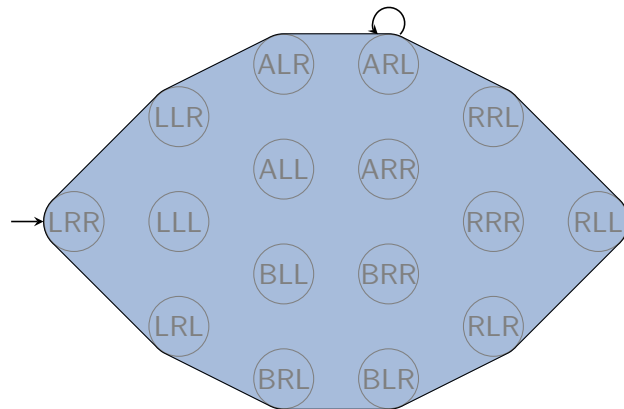

One-state abstraction:  $\alpha(s) := \text{const.}$

- + very few abstract states and succinct encoding for  $\alpha$
- completely uninformative heuristic

## Counterexample: Identity Abstraction

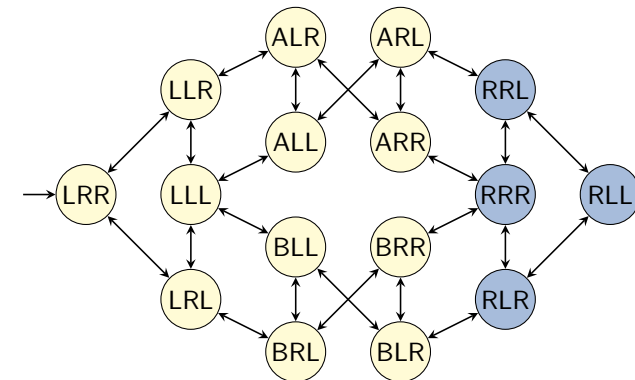

Identity abstraction:  $\alpha(s) := s$ .

- + perfect heuristic and succinct encoding for  $\alpha$
- too many abstract states

## Counterexample: Perfect Abstraction

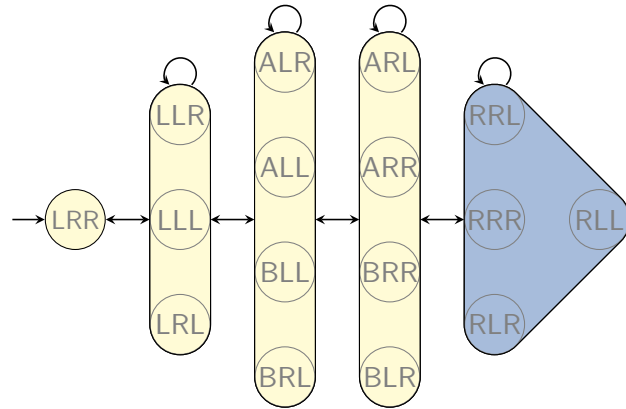

Perfect abstraction:  $\alpha(s) := h^*(s)$ .

- + perfect heuristic and usually few abstract states
- usually no succinct encoding for  $\alpha$

## Automatically Deriving Good Abstraction Heuristics

Abstraction Heuristics for Planning: Main Research Problem  
 Automatically derive effective abstraction heuristics  
 for planning tasks.

- ~> we will study two state-of-the-art approaches  
 in Chapters D4–D8

## D3.3 Summary

### Summary

- ▶ Abstraction heuristics from **orthogonal** abstractions can be **added** without losing admissibility or consistency.
- ▶ One sufficient condition for orthogonality is that all abstractions are **affected** by **disjoint** sets of **labels**.
- ▶ Practically useful abstractions are those which give **informative heuristics**, yet have a **small representation**.
- ▶ Coming up with **good abstractions automatically** is the main research challenge when applying abstraction heuristics in planning.