

Planning and Optimization

D2. Abstractions: Formal Definition and Heuristics

Malte Helmert and Gabriele Röger

Universität Basel

Content of this Course

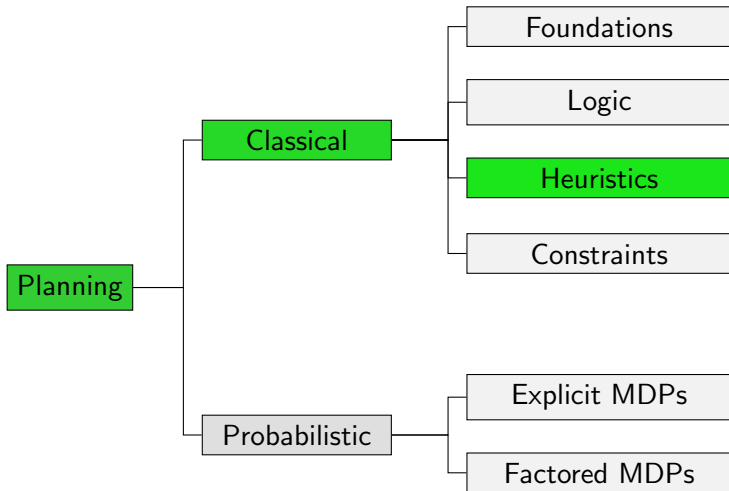

Content of this Course: Heuristics

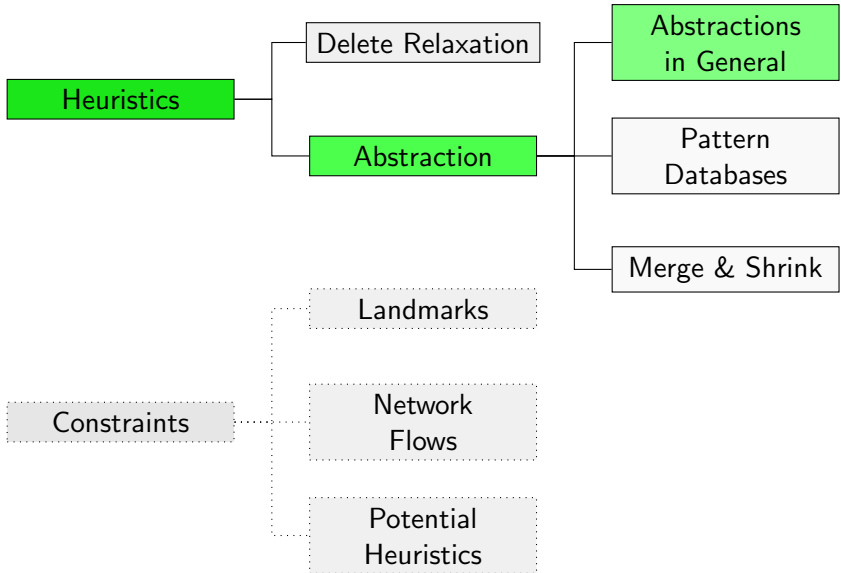

Reminder: Transition Systems

Transition Systems

Reminder from Chapter A3:

Definition (Transition System)

A **transition system** is a 6-tuple $\mathcal{T} = \langle S, L, c, T, s_0, S_\star \rangle$ where

- S is a finite set of **states**,
- L is a finite set of (transition) **labels**,
- $c : L \rightarrow \mathbb{R}_0^+$ is a **label cost** function,
- $T \subseteq S \times L \times S$ is the **transition relation**,
- $s_0 \in S$ is the **initial state**, and
- $S_\star \subseteq S$ is the set of **goal states**.

We say that \mathcal{T} **has the transition** $\langle s, \ell, s' \rangle$ if $\langle s, \ell, s' \rangle \in T$.

We also write this as $s \xrightarrow{\ell} s'$, or $s \rightarrow s'$ when not interested in ℓ .

Note: Transition systems are also called **state spaces**.

Transition Systems: Example

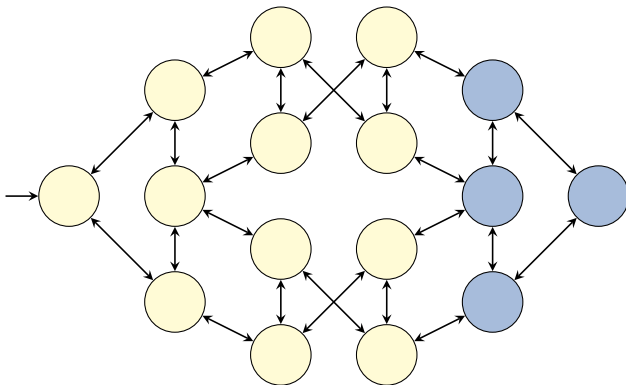

Note: To reduce clutter, our figures often omit arc labels and costs and collapse transitions between identical states. However, these are important for the formal definition of the transition system.

Mapping Planning Tasks to Transition Systems

Reminder from Chapter A3:

Definition (Transition System Induced by a Planning Task)

The planning task $\Pi = \langle V, I, O, \gamma \rangle$ **induces** the transition system $\mathcal{T}(\Pi) = \langle S, L, c, T, s_0, S_\star \rangle$, where

- S is the set of all states over state variables V ,
- L is the set of operators O ,
- $c(o) = \text{cost}(o)$ for all operators $o \in O$,
- $T = \{ \langle s, o, s' \rangle \mid s \in S, o \text{ applicable in } s, s' = s[o] \}$,
- $s_0 = I$, and
- $S_\star = \{ s \in S \mid s \models \gamma \}$.

Tasks in Finite-Domain Representation

Notes:

- We will focus on planning tasks in **finite-domain representation** (FDR) while studying abstractions.
- All concepts apply equally to propositional planning tasks.
- However, FDR tasks are almost always used by algorithms in this context because they tend to have fewer **useless** (physically impossible) states.
- Useless states can hurt the efficiency of abstraction-based algorithms.

Example Task: One Package, Two Trucks

Example (One Package, Two Trucks)

Consider the following FDR planning task $\langle V, I, O, \gamma \rangle$:

- $V = \{p, t_A, t_B\}$ with
 - $\text{dom}(p) = \{L, R, A, B\}$
 - $\text{dom}(t_A) = \text{dom}(t_B) = \{L, R\}$
- $I = \{p \mapsto L, t_A \mapsto R, t_B \mapsto R\}$
- $O = \{\text{pickup}_{i,j} \mid i \in \{A, B\}, j \in \{L, R\}\}$
 $\cup \{\text{drop}_{i,j} \mid i \in \{A, B\}, j \in \{L, R\}\}$
 $\cup \{\text{move}_{i,j,j'} \mid i \in \{A, B\}, j, j' \in \{L, R\}, j \neq j'\}$, where
 - $\text{pickup}_{i,j} = \langle t_i = j \wedge p = j, p := i, 1 \rangle$
 - $\text{drop}_{i,j} = \langle t_i = j \wedge p = i, p := j, 1 \rangle$
 - $\text{move}_{i,j,j'} = \langle t_i = j, t_i := j', 1 \rangle$
- $\gamma = (p = R)$

Transition System of Example Task

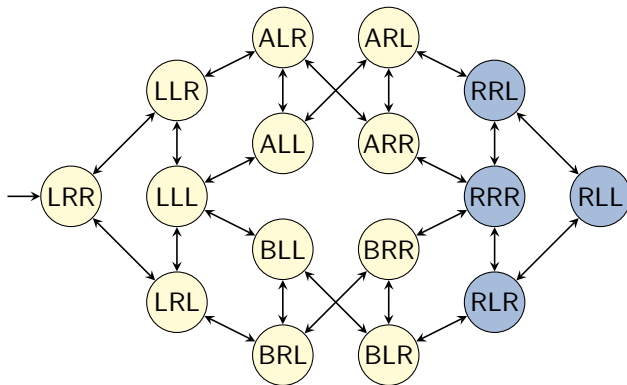

- State $\{p \mapsto i, t_A \mapsto j, t_B \mapsto k\}$ is depicted as ijk .
- Transition labels are again not shown. For example, the transition from LLL to ALL has the label $\text{pickup}_{A,L}$.

Abstractions

Abstractions

Definition (Abstraction)

Let $\mathcal{T} = \langle S, L, c, T, s_0, S_\star \rangle$ be a transition system.

An **abstraction** (also: **abstraction** function, **abstraction mapping**) of \mathcal{T} is a function $\alpha : S \rightarrow S^\alpha$ defined on the states of \mathcal{T} , where S^α is an arbitrary set.

Without loss of generality, we require that α is surjective.

Intuition: α maps the states of \mathcal{T} to another (usually smaller) **abstract** state space.

Abstract Transition System

Definition (Abstract Transition System)

Let $\mathcal{T} = \langle S, L, c, T, s_0, S_\star \rangle$ be a transition system, and let $\alpha : S \rightarrow S^\alpha$ be an abstraction of \mathcal{T} .

The **abstract transition system induced by α** , in symbols \mathcal{T}^α , is the transition system $\mathcal{T}^\alpha = \langle S^\alpha, L, c, T^\alpha, s_0^\alpha, S_\star^\alpha \rangle$ defined by:

- $T^\alpha = \{ \langle \alpha(s), \ell, \alpha(t) \rangle \mid \langle s, \ell, t \rangle \in T \}$
- $s_0^\alpha = \alpha(s_0)$
- $S_\star^\alpha = \{ \alpha(s) \mid s \in S_\star \}$

Concrete and Abstract State Space

Let \mathcal{T} be a transition system and α be an abstraction of \mathcal{T} .

- \mathcal{T} is called the **concrete transition system**.
- \mathcal{T}^α is called the **abstract transition system**.
- Similarly: **concrete/abstract state space**,
concrete/abstract transition, etc.

Abstraction: Example

concrete transition system

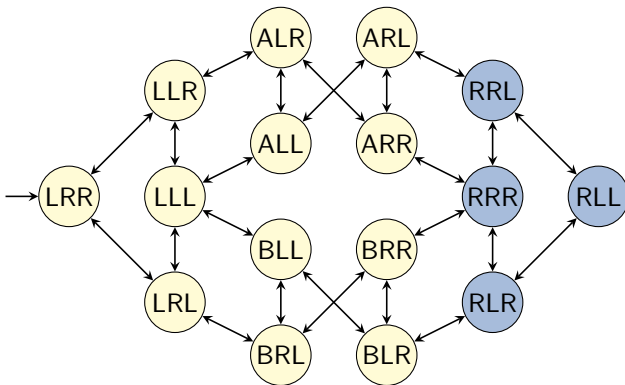

Abstraction: Example

abstract transition system

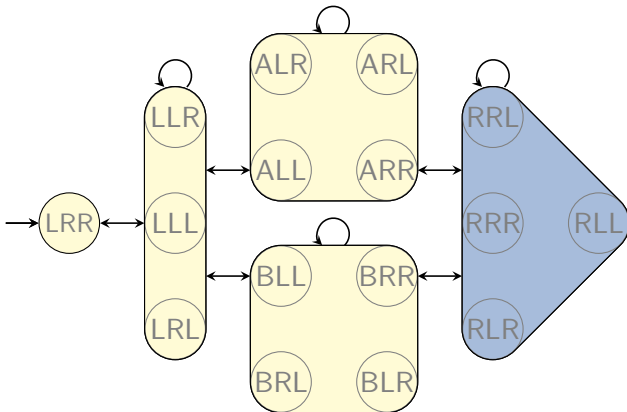

Note: Most arcs represent many parallel transitions.

Homomorphisms and Isomorphisms

Homomorphisms and Isomorphisms

- The abstraction mapping α that transforms \mathcal{T} to \mathcal{T}^α is also called a **strict homomorphism** from \mathcal{T} to \mathcal{T}^α .
- Roughly speaking, in mathematics a **homomorphism** is a property-preserving mapping between structures.
- A **strict** homomorphism is one where no additional features are introduced. A non-strict homomorphism in planning would mean that the abstract transition system may include additional transitions and goal states not induced by α .
- We only consider strict homomorphisms in this course.
- If α is bijective, it is called an **isomorphism** between \mathcal{T} and \mathcal{T}^α , and the two transition systems are called **isomorphic**.

Isomorphic Transition Systems

The notion of isomorphic transition systems is important enough to warrant a formal definition:

Definition (Isomorphic Transition Systems)

Let $\mathcal{T} = \langle S, L, c, T, s_0, S_\star \rangle$ and $\mathcal{T}' = \langle S', L', c', T', s'_0, S'_\star \rangle$ be transition systems.

We say that \mathcal{T} is **isomorphic to** \mathcal{T}' , in symbols $\mathcal{T} \sim \mathcal{T}'$, if there exist bijective functions $\varphi : S \rightarrow S'$ and $\lambda : L \rightarrow L'$ such that:

- $s \xrightarrow{\ell} t \in T$ iff $\varphi(s) \xrightarrow{\lambda(\ell)} \varphi(t) \in T'$,
- $c'(\lambda(\ell)) = c(\ell)$ for all $\ell \in L$,
- $\varphi(s_0) = s'_0$, and
- $s \in S_\star$ iff $\varphi(s) \in S'_\star$.

Graph-Equivalent Transition Systems

Sometimes a weaker notion of equivalence is useful:

Definition (Graph-Equivalent Transition Systems)

Let $\mathcal{T} = \langle S, L, c, T, s_0, S_\star \rangle$ and $\mathcal{T}' = \langle S', L', c', T', s'_0, S'_\star \rangle$ be transition systems.

We say that \mathcal{T} is **graph-equivalent to** \mathcal{T}' , in symbols $\mathcal{T} \stackrel{G}{\sim} \mathcal{T}'$, if there exists a bijective function $\varphi : S \rightarrow S'$ such that:

- There is a transition $s \xrightarrow{\ell} t \in T$ with $c(\ell) = k$ iff there is a transition $\varphi(s) \xrightarrow{\ell'} \varphi(t) \in T'$ with $c'(\ell') = k$,
- $\varphi(s_0) = s'_0$, and
- $s \in S_\star$ iff $\varphi(s) \in S'_\star$.

Note: The labels of \mathcal{T} and \mathcal{T}' do not matter except that transitions **of the same cost** must be preserved.

Isomorphism vs. Graph Equivalence

- (\sim) and $(\overset{G}{\sim})$ are equivalence relations.
- Two isomorphic transition systems are interchangeable for all practical intents and purposes.
- Two graph-equivalent transition systems are interchangeable for most intents and purposes.
- In particular, their goal distances are identical.
- Isomorphism implies graph equivalence, but not vice versa.

Abstraction Heuristics

Abstraction Heuristics

Definition (Abstraction Heuristic)

Let $\alpha : S \rightarrow S^\alpha$ be an abstraction of a transition system \mathcal{T} .

The **abstraction heuristic induced by α** , written h^α , is the heuristic function $h^\alpha : S \rightarrow \mathbb{R}_0^+ \cup \{\infty\}$ defined as

$$h^\alpha(s) = h_{\mathcal{T}^\alpha}^*(\alpha(s)) \quad \text{for all } s \in S,$$

where $h_{\mathcal{T}^\alpha}^*$ denotes the goal distance function in \mathcal{T}^α .

Notes:

- $h^\alpha(s) = \infty$ if no goal state of \mathcal{T}^α is reachable from $\alpha(s)$
- We also apply abstraction terminology to planning tasks Π , which stand for their induced transition systems.
For example, an **abstraction of Π** is an abstraction of $\mathcal{T}(\Pi)$.

Abstraction Heuristics: Example

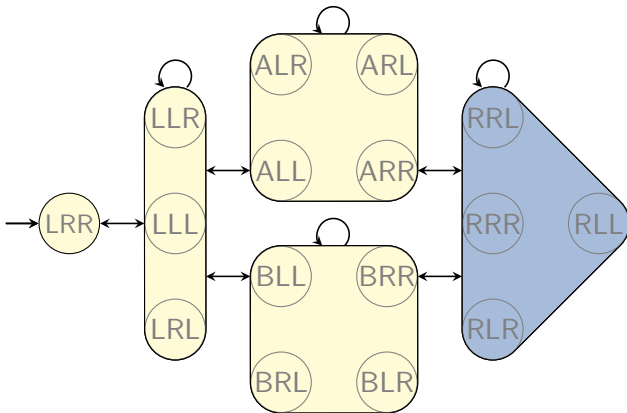

$$h^\alpha(\{p \mapsto L, t_A \mapsto R, t_B \mapsto R\}) = 3$$

Consistency of Abstraction Heuristics (1)

Theorem (Consistency and Admissibility of h^α)

Let α be an abstraction of a transition system \mathcal{T} .

Then h^α is safe, goal-aware, admissible and consistent.

Proof.

We prove goal-awareness and consistency;
the other properties follow from these two.

Let $\mathcal{T} = \langle S, L, c, T, s_0, S_\star \rangle$.

Let $\mathcal{T}^\alpha = \langle S^\alpha, L, c, T^\alpha, s_0^\alpha, S_\star^\alpha \rangle$.

Consistency of Abstraction Heuristics (1)

Theorem (Consistency and Admissibility of h^α)

Let α be an abstraction of a transition system \mathcal{T} .

Then h^α is safe, goal-aware, admissible and consistent.

Proof.

We prove goal-awareness and consistency;
the other properties follow from these two.

Let $\mathcal{T} = \langle S, L, c, T, s_0, S_\star \rangle$.

Let $\mathcal{T}^\alpha = \langle S^\alpha, L, c, T^\alpha, s_0^\alpha, S_\star^\alpha \rangle$.

Goal-awareness: We need to show that $h^\alpha(s) = 0$ for all $s \in S_\star$,
so let $s \in S_\star$. Then $\alpha(s) \in S_\star^\alpha$ by the definition of abstract
transition systems, and hence $h^\alpha(s) = h_{\mathcal{T}^\alpha}^*(\alpha(s)) = 0$

Consistency of Abstraction Heuristics (2)

Proof (continued).

Consistency: Consider any state transition $s \xrightarrow{\ell} t$ of \mathcal{T} .
We need to show $h^\alpha(s) \leq c(\ell) + h^\alpha(t)$.

Consistency of Abstraction Heuristics (2)

Proof (continued).

Consistency: Consider any state transition $s \xrightarrow{\ell} t$ of \mathcal{T} .

We need to show $h^\alpha(s) \leq c(\ell) + h^\alpha(t)$.

By the definition of \mathcal{T}^α , we get $\alpha(s) \xrightarrow{\ell} \alpha(t) \in \mathcal{T}^\alpha$.

Hence, $\alpha(t)$ is a successor of $\alpha(s)$ in \mathcal{T}^α via the label ℓ .

Consistency of Abstraction Heuristics (2)

Proof (continued).

Consistency: Consider any state transition $s \xrightarrow{\ell} t$ of \mathcal{T} .
We need to show $h^\alpha(s) \leq c(\ell) + h^\alpha(t)$.

By the definition of \mathcal{T}^α , we get $\alpha(s) \xrightarrow{\ell} \alpha(t) \in \mathcal{T}^\alpha$.
Hence, $\alpha(t)$ is a successor of $\alpha(s)$ in \mathcal{T}^α via the label ℓ .

We get:

$$\begin{aligned} h^\alpha(s) &= h_{\mathcal{T}^\alpha}^*(\alpha(s)) \\ &\leq c(\ell) + h_{\mathcal{T}^\alpha}^*(\alpha(t)) \\ &= c(\ell) + h^\alpha(t), \end{aligned}$$

where the inequality holds because perfect goal distances $h_{\mathcal{T}^\alpha}^*$ are consistent in \mathcal{T}^α .

(The shortest path from $\alpha(s)$ to the goal in \mathcal{T}^α cannot be longer than the shortest path from $\alpha(s)$ to the goal via $\alpha(t)$.) □

Coarsenings and Refinements

Abstractions of Abstractions

Since abstractions map transition systems to transition systems, they are **composable**:

- Using a first abstraction $\alpha : S \rightarrow S'$, map \mathcal{T} to \mathcal{T}^α .
- Using a second abstraction $\beta : S' \rightarrow S''$, map \mathcal{T}^α to $(\mathcal{T}^\alpha)^\beta$.

The result is **the same** as directly using the abstraction $(\beta \circ \alpha)$:

- Let $\gamma : S \rightarrow S''$ be defined as $\gamma(s) = (\beta \circ \alpha)(s) = \beta(\alpha(s))$.
- Then $\mathcal{T}^\gamma = (\mathcal{T}^\alpha)^\beta$.

Abstractions of Abstractions: Example (1)

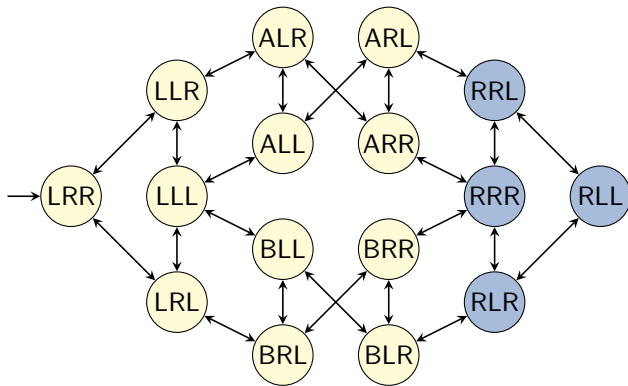

transition system \mathcal{T}

Abstractions of Abstractions: Example (2)

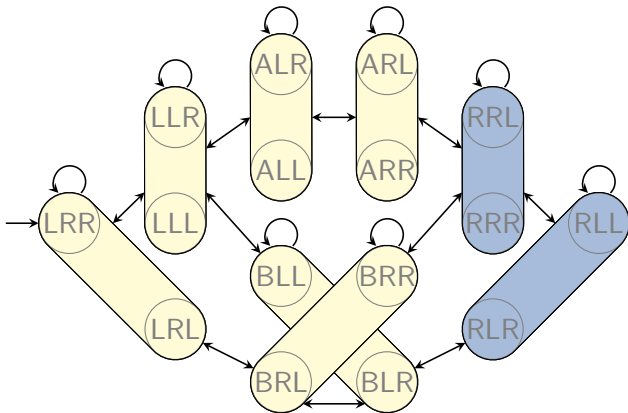

Transition system \mathcal{T}' as an abstraction of \mathcal{T}

Abstractions of Abstractions: Example (2)

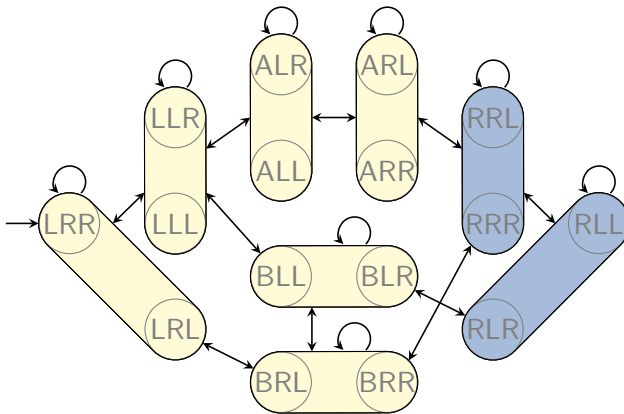

Transition system \mathcal{T}' as an abstraction of \mathcal{T}

Abstractions of Abstractions: Example (3)

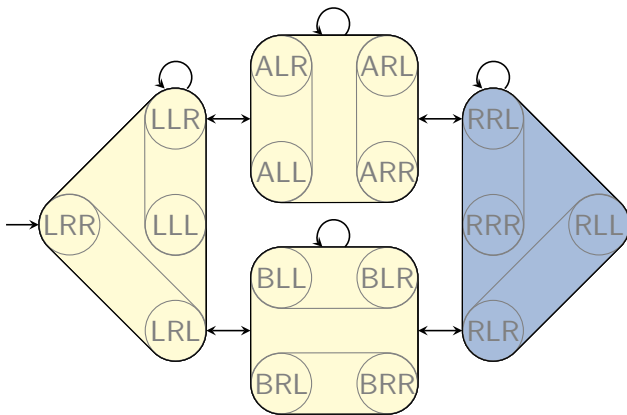

Transition system \mathcal{T}'' as an abstraction of \mathcal{T}'

Abstractions of Abstractions: Example (3)

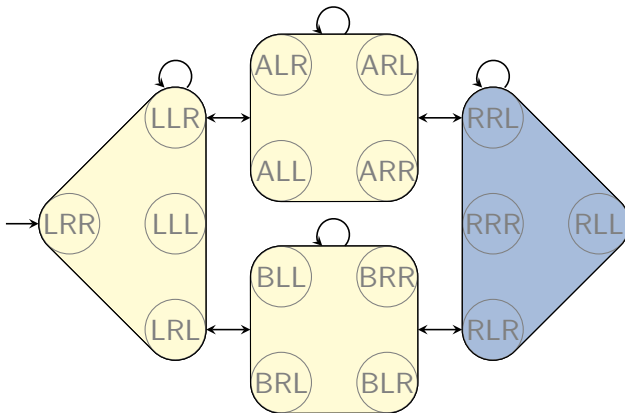

Transition system \mathcal{T}'' as an abstraction of \mathcal{T}

Coarsenings and Refinements

Definition (Coarsening and Refinement)

Let α and γ be abstractions of the same transition system such that $\gamma = \beta \circ \alpha$ for some function β .

Then γ is called a **coarsening** of α and α is called a **refinement** of γ .

Heuristic Quality of Refinements

Theorem (Heuristic Quality of Refinements)

Let α and γ be abstractions of the same transition system such that α is a refinement of γ .

Then h^α dominates h^γ .

In other words, $h^\gamma(s) \leq h^\alpha(s) \leq h^*(s)$ for all states s .

Heuristic Quality of Refinements: Proof

Proof.

Since α is a refinement of γ ,
there exists a function β with $\gamma = \beta \circ \alpha$.

For all states s of Π , we get:

$$\begin{aligned} h^\gamma(s) &= h_{\mathcal{T}^\gamma}^*(\gamma(s)) \\ &= h_{\mathcal{T}^\gamma}^*(\beta(\alpha(s))) \\ &= h_{\mathcal{T}^\alpha}^\beta(\alpha(s)) \\ &\leq h_{\mathcal{T}^\alpha}^*(\alpha(s)) \\ &= h^\alpha(s), \end{aligned}$$

where the inequality holds because $h_{\mathcal{T}^\alpha}^\beta$ is an admissible heuristic in the transition system \mathcal{T}^α . □

Summary

Summary

- An **abstraction** is a function α that maps the states S of a transition system to another (usually smaller) set S^α .
- This **induces** an abstract transition system \mathcal{T}^α , which behaves like the original transition system \mathcal{T} except that states mapped to the same abstract state cannot be distinguished.
- Abstractions α induce **abstraction heuristics** h^α : $h^\alpha(s)$ is the goal distance of $\alpha(s)$ in the abstract transition system.
- Abstraction heuristics are **safe, goal-aware, admissible** and **consistent**.
- Abstractions can be composed, leading to **coarser** vs. **finer** abstractions. Heuristics for finer abstractions dominate those for coarser ones.