

# Planning and Optimization

## D3. Pattern Databases: Introduction

Gabriele Röger and Thomas Keller

Universität Basel

October 31, 2018

# Content of this Course

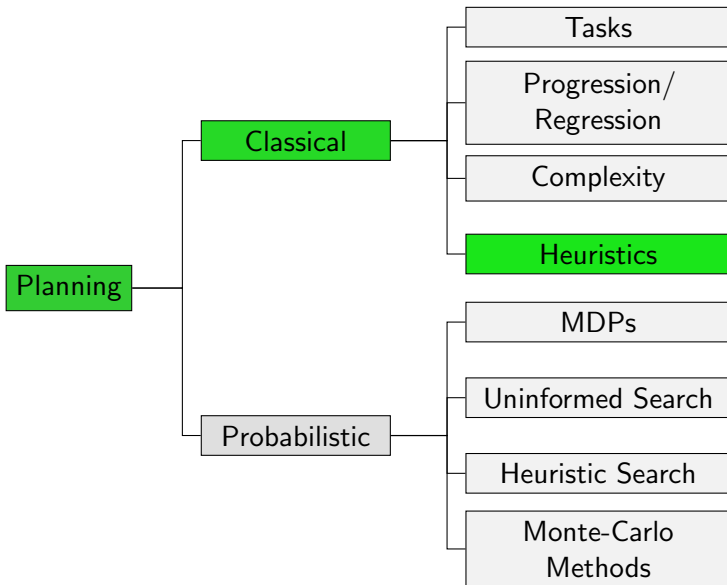

# Content of this Course: Heuristics

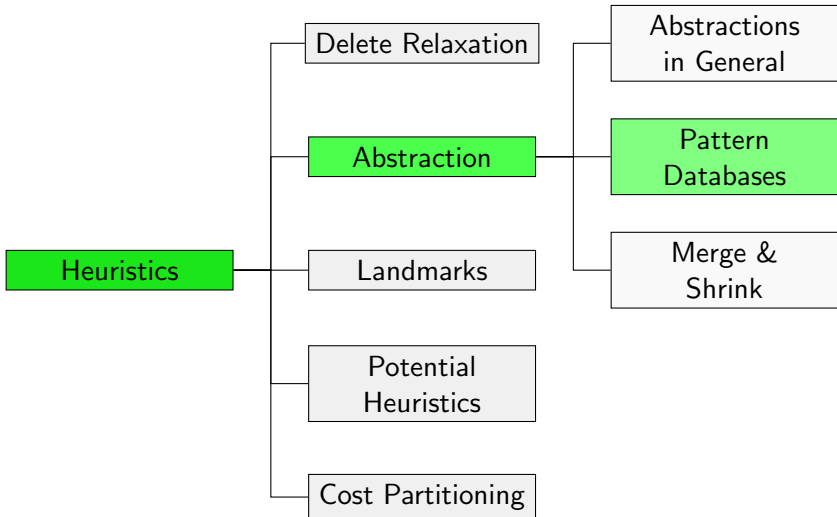

# Projections and Pattern Database Heuristics

# Pattern Database Heuristics

- The most commonly used abstraction heuristics in search and planning are **pattern database (PDB) heuristics**.
- PDB heuristics were originally introduced for the **15-puzzle** (Culberson & Schaeffer, 1996) and for **Rubik's cube** (Korf, 1997).
- The first use for **domain-independent planning** is due to Edelkamp (2001).
- Since then, much research has focused on the theoretical properties of pattern databases, how to use pattern databases more effectively, how to find good patterns, etc.
- Pattern databases are a **very active research area** both in planning and in (domain-specific) heuristic search.
- For many search problems, pattern databases are the **most effective admissible heuristics** currently known.

# Pattern Database Heuristics Informally

## Pattern Databases: Informally

A pattern database heuristic for a planning task is an abstraction heuristic where

- some aspects of the task are represented in the abstraction **with perfect precision**, while
- all other aspects of the task are **not represented at all**.

This is achieved by **projecting** the task onto those variables that describe the aspects that are represented.

## Example: Transition System

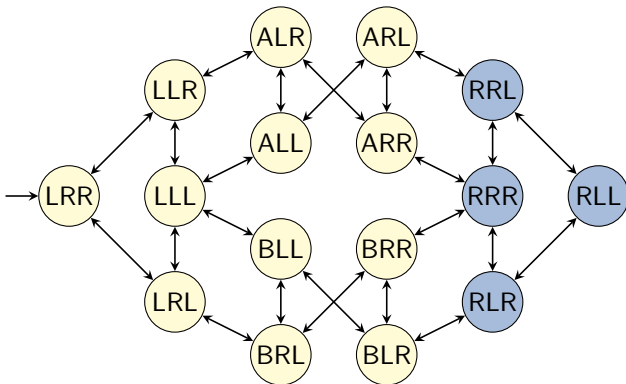

Logistics problem with one package, two trucks, two locations:

- state variable **package**:  $\{L, R, A, B\}$
- state variable **truck A**:  $\{L, R\}$
- state variable **truck B**:  $\{L, R\}$

## Example: Projection (1)

Abstraction induced by  $\pi_{\{\text{package}\}}$ :

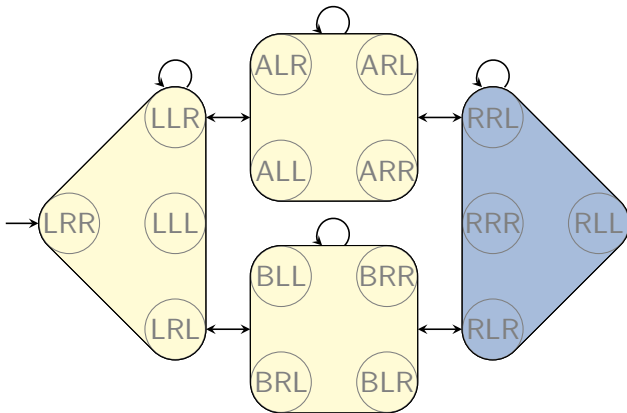

$$h^{\{\text{package}\}}(\text{LRR}) = 2$$



## Example: Projection (2)

Abstraction induced by  $\pi_{\{\text{package, truck A}\}}$ :

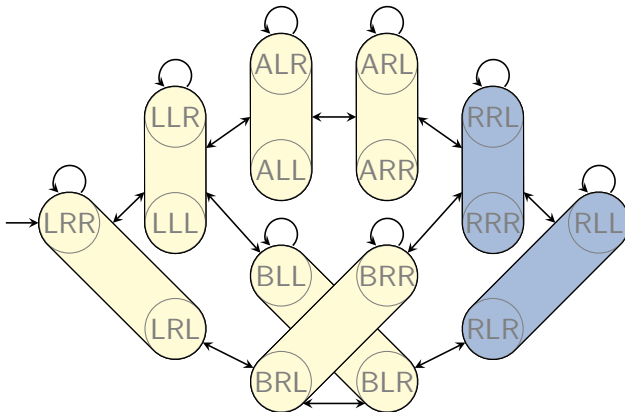

$$h_{\{\text{package, truck A}\}}(\text{LRR}) = 2$$

## Example: Projection (2)

Abstraction induced by  $\pi_{\{\text{package, truck A}\}}$ :

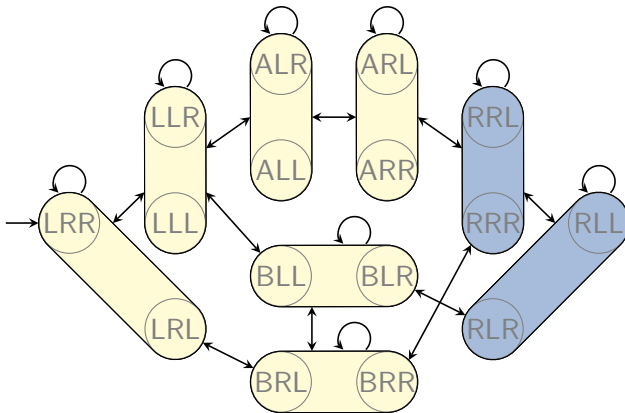

$$h_{\{\text{package, truck A}\}}(\text{LRR}) = 2$$

# Projections

Formally, pattern database heuristics are abstraction heuristics induced by a particular class of abstractions called **projections**.

## Definition (Projection)

Let  $\Pi$  be an FDR planning task with variables  $V$  and states  $S$ . Let  $P \subseteq V$ , and let  $S'$  be the set of states over  $P$ .

The **projection**  $\pi_P : S \rightarrow S'$  is defined as  $\pi_P(s) := s|_P$ , where  $s|_P(v) := s(v)$  for all  $v \in P$ .

We call  $P$  the **pattern** of the projection  $\pi_P$ .

In other words,  $\pi_P$  maps two states  $s_1$  and  $s_2$  to the same abstract state iff they agree on all variables in  $P$ .

# Pattern Database Heuristics

Abstraction heuristics based on projections are called **pattern database (PDB)** heuristics.

## Definition (Pattern Database Heuristic)

The abstraction heuristic induced by  $\pi_P$  is called a **pattern database heuristic** or **PDB heuristic**.

We write  $h^P$  as a shorthand for  $h^{\pi_P}$ .

Why are they called **pattern database heuristics**?

- Heuristic values for PDB heuristics are traditionally stored in a 1-dimensional table (array) called a **pattern database (PDB)**. Hence the name “PDB heuristic”.

# Pattern Databases: Chapter Overview

In the following, we will discuss:

- how to **implement** PDB heuristics  
    ↪ this chapter
- how to effectively make use of **multiple** PDB heuristics  
    ↪ Chapter D4
- how to **find good patterns** for PDB heuristics  
    ↪ Chapter D5

# Pattern Database Implementation

Assume we are given a pattern  $P$  for a planning task  $\Pi$ .

How do we implement  $h^P$ ?

- 1 In a **precomputation** step, we compute a graph representation for the abstraction  $\mathcal{T}(\Pi)^{\pi_P}$  and compute the abstract goal distance for each abstract state.
- 2 During search, we use the precomputed abstract goal distances in a **lookup** step.

# Implementing PDBs: Precomputation

## Precomputation Step

Let  $\Pi$  be a planning task and  $P$  a pattern.

Let  $\mathcal{T} = \mathcal{T}(\Pi)$  and  $\mathcal{T}' = \mathcal{T}^{\pi_P}$ .

- We want to compute a graph representation of  $\mathcal{T}'$ .
- $\mathcal{T}'$  is defined through an abstraction of  $\mathcal{T}$ .
  - For example, each concrete transition induces an abstract transition.
- However, we cannot **compute**  $\mathcal{T}'$  by iterating over all transitions of  $\mathcal{T}$ .
  - This would take time  $\Omega(\|\mathcal{T}\|)$ .
  - This is prohibitively long (so long that we could solve the task using uniform-cost search or similar techniques).
- Hence, we need a way of computing  $\mathcal{T}'$  in time which is **polynomial only in  $\|\Pi\|$  and  $\|\mathcal{T}'\|$** .



# Syntactic Projections

## Definition (Syntactic Projection)

Let  $\Pi = \langle V, I, O, \gamma \rangle$  be an FDR planning task, and let  $P \subseteq V$  be a subset of its variables.

The **syntactic projection**  $\Pi|_P$  of  $\Pi$  to  $P$  is the FDR planning task  $\langle P, I|_P, \{o|_P \mid o \in O\}, \gamma|_P \rangle$ , where

- $\varphi|_P$  for formula  $\varphi$  is defined as the formula obtained from  $\varphi$  by replacing all atoms  $(v = d)$  with  $v \notin P$  by  $\top$ , and
- $o|_P$  for operator  $o$  is defined by replacing all formulas  $\varphi$  occurring in the precondition or effect conditions of  $o$  with  $\varphi|_P$  and all atomic effects  $(v := d)$  with  $v \notin P$  with the empty effect  $\top$ .

Put simply,  $\Pi|_P$  throws away all information not pertaining to variables in  $P$ .

# Trivially Inapplicable Operators

## Definition (Trivially Inapplicable Operator)

An operator  $o$  of a  $SAS^+$  task is called **trivially inapplicable** if

- $pre(o)$  contains the atoms  $(v = d)$  and  $(v = d')$  for some variable  $v$  and values  $d \neq d'$ , or
- $eff(o)$  contains the effects  $(v := d)$  and  $(v := d')$  for some variable  $v$  and values  $d \neq d'$ .

### Notes:

- Trivially inapplicable operators are never applicable and can thus be safely omitted from the task.
- Trivially inapplicable operators can be detected in linear time.

# Trivially Unsolvable SAS<sup>+</sup> Tasks

## Definition (Trivially Unsolvable)

A SAS<sup>+</sup> task  $\Pi = \langle V, I, O, \gamma \rangle$  is called **trivially unsolvable** if  $\gamma$  contains the atoms  $(v = d)$  and  $(v = d')$  for some variable  $v$  and values  $d \neq d'$ .

### Notes:

- Trivially unsolvable SAS<sup>+</sup> tasks have no goal states and are hence unsolvable.
- Trivially unsolvable SAS<sup>+</sup> tasks can be detected in linear time.

# Equivalence Theorem for Syntactic Projections

## Theorem (Syntactic Projections vs. Projections)

*Let  $\Pi$  be a SAS<sup>+</sup> task that is not trivially unsolvable and has no trivially inapplicable operators, and let  $P$  be a pattern for  $\Pi$ .*

*Then  $\mathcal{T}(\Pi|_P) \stackrel{G}{\sim} \mathcal{T}(\Pi)^{\pi_P}$ .*

Proof.

↪ exercises



# PDB Computation

Using the equivalence theorem, we can compute pattern databases for (not trivially unsolvable)  $SAS^+$  tasks  $\Pi$  and patterns  $P$ :

## Computing Pattern Databases

**def** compute-PDB( $\Pi$ ,  $P$ ):

Remove trivially inapplicable operators from  $\Pi$ .

Compute  $\Pi' := \Pi|_P$ .

Compute  $\mathcal{T}' := \mathcal{T}(\Pi')$ .

Perform a backward uniform-cost search from the goal states of  $\mathcal{T}'$  to compute all abstract goal distances.

$PDB :=$  a table containing all goal distances in  $\mathcal{T}'$

**return**  $PDB$

The algorithm runs **in polynomial time and space** in terms of  $\|\Pi\| + |PDB|$ .

# Generalizations of the Equivalence Theorem

- The restrictions to  $SAS^+$  tasks and to tasks without trivially inapplicable operators are necessary.
- We can slightly generalize the result if we allow general negation-free formulas, but still forbid conditional effects.
  - In that case, the weighted graph of  $\mathcal{T}(\Pi)^{\pi_P}$  is isomorphic to a subgraph of the weighted graph of  $\mathcal{T}(\Pi|_P)$ .
  - This means that we can use  $\mathcal{T}(\Pi|_P)$  to derive an admissible estimate of  $h^P$ .
- With conditional effects, not even this weaker result holds.

## Going Beyond SAS<sup>+</sup> Tasks

- Most practical implementations of PDB heuristics are limited to SAS<sup>+</sup> tasks (or modest generalizations).
  - One way to avoid the issues with general FDR tasks is to convert them to equivalent SAS<sup>+</sup> tasks.
  - However, most direct conversions can exponentially increase the task size in the worst case.
- ↪ We will only consider SAS<sup>+</sup> tasks in the chapters dealing with pattern databases.

# Implementing PDBs: Lookup



## Lookup Step: Overview

- During search, the PDB is the only piece of information necessary to represent  $h^P$ . (It is not necessary to store the abstract transition system itself at this point.)
- Hence, the space requirements for PDBs during search are linear in the number of abstract states  $S'$ : there is one table entry for each abstract state.
- During search,  $h^P(s)$  is computed by mapping  $\pi_P(s)$  to a natural number in the range  $\{0, \dots, |S'| - 1\}$  using a **perfect hash function**, then looking up the table entry for this number.

## Lookup Step: Algorithm

Let  $P = \{v_1, \dots, v_k\}$  be the pattern.

- We assume that all variable domains are natural numbers counted from 0, i.e.,  $\text{dom}(v) = \{0, 1, \dots, |\text{dom}(v)| - 1\}$ .
- For all  $i \in \{1, \dots, k\}$ , we precompute  $N_i := \prod_{j=1}^{i-1} |\text{dom}(v_j)|$ .

Then we can look up heuristic values as follows:

### Computing Pattern Database Heuristics

```
def PDB-heuristic(s):
    index :=  $\sum_{i=1}^k N_i s(v_i)$ 
    return PDB[index]
```

- This is a **very fast** operation: it can be performed in  $O(k)$ .
- For comparison, most relaxation heuristics need time  $O(\|\Pi\|)$  per state.

# Lookup Step: Example (1)

Abstraction induced by  $\pi_{\{\text{package}, \text{truck A}\}}$ :

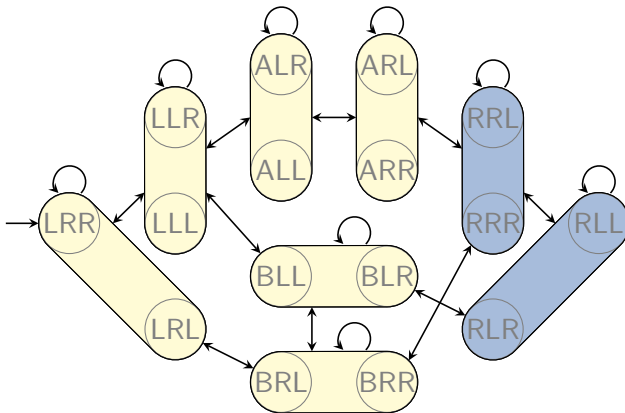

## Lookup Step: Example (2)

- $P = \{v_1, v_2\}$  with  $v_1 = \text{package}$ ,  $v_2 = \text{truck A}$ .
- $\text{dom}(v_1) = \{L, R, A, B\} \approx \{0, 1, 2, 3\}$
- $\text{dom}(v_2) = \{L, R\} \approx \{0, 1\}$

$$\rightsquigarrow N_1 = \prod_{j=1}^0 |\text{dom}(v_j)| = 1, N_2 = \prod_{j=1}^1 |\text{dom}(v_j)| = 4$$

$$\rightsquigarrow \text{index}(s) = 1 \cdot s(\text{package}) + 4 \cdot s(\text{truck A})$$

Pattern database:

abstract state	LL	RL	AL	BL	LR	RR	AR	BR
index	0	1	2	3	4	5	6	7
value	2	0	2	1	2	0	1	1

# Summary

# Summary

- **Pattern database (PDB) heuristics** are abstraction heuristics based on **projection** to a subset of variables.
- For  $SAS^+$  tasks, they can easily be implemented via **syntactic projections** of the task representation.
- PDBs are **lookup tables** that store heuristic values, indexed by **perfect hash values** for projected states.
- PDB values can be looked up **very fast**, in time  $O(k)$  for a projection to  $k$  variables.