

Theory of Computer Science

C7. Context-Sensitive and Type-0 Languages: Turing Machines

Gabriele Röger

University of Basel

April 3, 2019

Theory of Computer Science

April 3, 2019 — C7. Context-Sensitive and Type-0 Languages: Turing Machines

C7.1 Context-Sensitive and General Grammars

C7.2 Turing Machines

C7.3 Summary

Overview

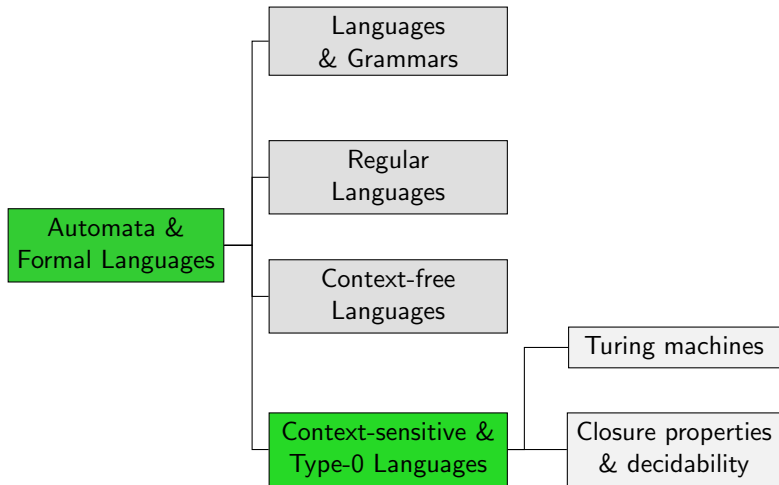

C7.1 Context-Sensitive and General Grammars

Repetition: (Context-Sensitive) Grammars

Definition (Grammar)

A **grammar** is a 4-tuple $\langle \Sigma, V, P, S \rangle$ with:

- ▶ Σ finite alphabet of terminal symbols
- ▶ V finite set of variables (with $V \cap \Sigma = \emptyset$)
- ▶ $P \subseteq (V \cup \Sigma)^+ \times (V \cup \Sigma)^*$ finite set of rules
- ▶ $S \in V$ start variable

Type 0 and type 1:

- ▶ **Every grammar is type 0.**
- ▶ A grammar is **context-sensitive (type-1)** if all rules $w_1 \rightarrow w_2$ satisfy $|w_1| \leq |w_2|$.
 - ▶ **only exception:** $S \rightarrow \varepsilon$ is allowed for the start symbol S if S never occurs on a right-hand side.

C7.2 Turing Machines

Overview

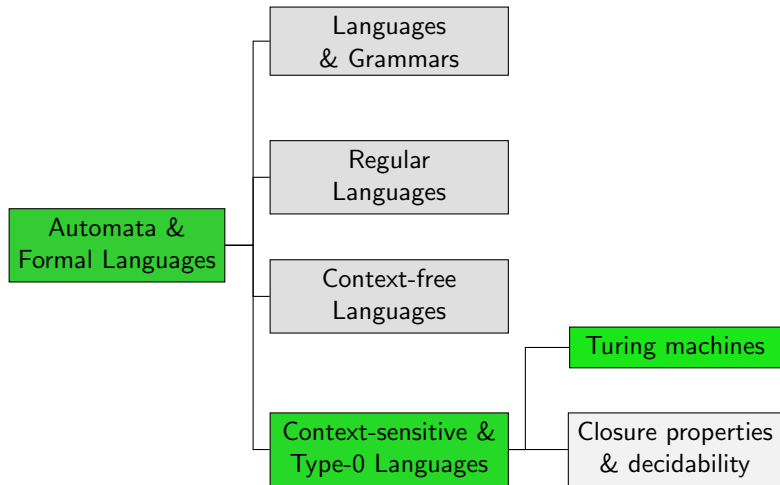

Automata for Type-1 and Type-0 Languages?



Finite automata accept exactly the regular languages, push-down automata exactly the context-free languages. Are there automata models for context-sensitive and type-0 languages?

Yes! \rightsquigarrow Turing machines
German: Turingmaschinen

Picture courtesy of [imagerymajestic](#) / [FreeDigitalPhotos.net](#)

Alan Turing (1912–1954)



Picture courtesy of Jon Callas /
wikimedia commons

- ▶ British logician, mathematician, cryptanalyst and computer scientist
- ▶ most important work (for us):
On Computable Numbers,
with an Application to the
Entscheidungsproblem
~> **Turing machines**
- ▶ collaboration on **Enigma decryption**
- ▶ conviction due to homosexuality;
pardoned by Elizabeth II in Dec. 2013
- ▶ **Turing award** most important
science award in computer science

Turing Machines: Conceptually

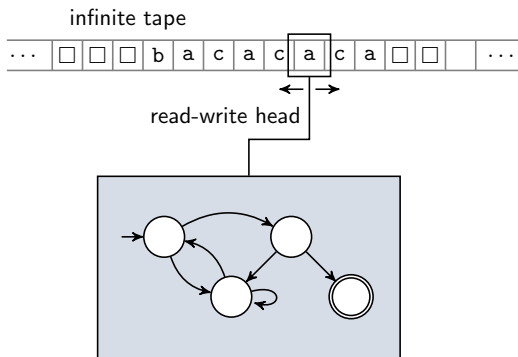

Nondeterministic Turing Machine: Definition

Definition (Nondeterministic Turing Machine)

A nondeterministic **Turing machine (NTM)** is given by a 7-tuple $M = \langle Q, \Sigma, \Gamma, \delta, q_0, \square, E \rangle$ with:

- ▶ Q finite non-empty set of **states**
- ▶ $\Sigma \neq \emptyset$ finite **input alphabet**
- ▶ $\Gamma \supset \Sigma$ finite **tape alphabet**
- ▶ $\delta : (Q \setminus E) \times \Gamma \rightarrow \mathcal{P}(Q \times \Gamma \times \{L, R, N\})$ **transition function**
- ▶ $q_0 \in Q$ **start state**
- ▶ $\square \in \Gamma \setminus \Sigma$ **blank symbol**
- ▶ $E \subseteq Q$ **end states**

German: Turingmaschine, Zustände, Eingabealphabet, Bandalphabet, Übergangsfunktion, Startzustand, Blank-Symbol, Endzustände

Turing Machine: Transition Function

Let $M = \langle Q, \Sigma, \Gamma, \delta, q_0, \square, E \rangle$ be an NTM.

What is the Intuitive Meaning of the Transition Function δ ?
 $\langle q', b, D \rangle \in \delta(q, a)$:

- ▶ If M is in state q and reads a , then
- ▶ M can transition to state q' in the next step,
- ▶ replacing a with b ,
- ▶ and moving the head in direction $D \in \{L, R, N\}$, where:
 - ▶ **L**: one step to the left,
 - ▶ **R**: one step to the right,
 - ▶ **N**: neutral (no) movement.

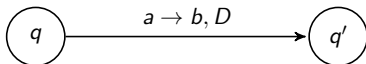

Nondeterministic Turing Machine: Example

$$M = \langle \{q_0, q_1, \dots, q_6\}, \{1, +, =\}, \{1, +, =, X, \square\}, \delta, q_0, \square, \{q_6\} \rangle$$

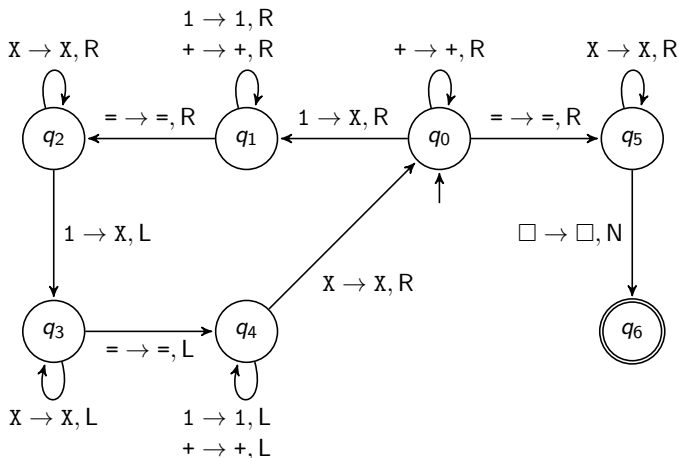

Turing Machine: Configuration

Definition (Configuration of a Turing Machine)

A **configuration** of a Turing machine $M = \langle Q, \Sigma, \Gamma, \delta, q_0, \square, E \rangle$ is given by a triple $c \in \Gamma^* \times Q \times \Gamma^+$.

German: Konfiguration

Configuration $\langle w_1, q, w_2 \rangle$ intuitively means that

- ▶ the non-empty or already visited part of the tape contains the word $w_1 w_2$,
- ▶ the read-write head is on the first symbol of w_2 , and
- ▶ the TM is in state q .

Turing Machine Configurations: Example

Example

configuration $\langle \square \text{BEFORE}, q, \text{AFTER} \square \square \rangle$.

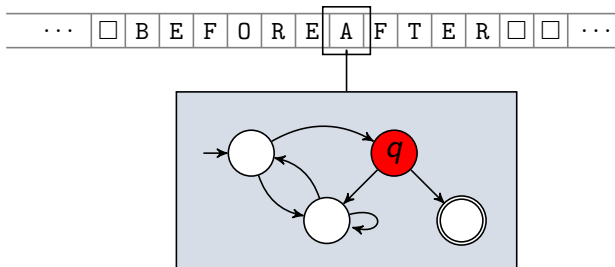

Turing Machine: Step

Definition (Transition/Step of a Turing Machine)

An NTM $M = \langle Q, \Sigma, \Gamma, \delta, q_0, \square, E \rangle$ can transition from configuration c to configuration c' in one step ($c \vdash_M c'$) according to the following rules:

- ▶ $\langle a_1 \dots a_m, q, b_1 \dots b_n \rangle \vdash_M \langle a_1 \dots a_m, q', cb_2 \dots b_n \rangle$
if $\langle q', c, N \rangle \in \delta(q, b_1)$, $m \geq 0$, $n \geq 1$
- ▶ $\langle a_1 \dots a_m, q, b_1 \dots b_n \rangle \vdash_M \langle a_1 \dots a_{m-1}, q', a_m cb_2 \dots b_n \rangle$
if $\langle q', c, L \rangle \in \delta(q, b_1)$, $m \geq 1$, $n \geq 1$
- ▶ $\langle \varepsilon, q, b_1 \dots b_n \rangle \vdash_M \langle \varepsilon, q', \square cb_2 \dots b_n \rangle$
if $\langle q', c, L \rangle \in \delta(q, b_1)$, $n \geq 1$
- ▶ $\langle a_1 \dots a_m, q, b_1 \dots b_n \rangle \vdash_M \langle a_1 \dots a_m c, q', b_2 \dots b_n \rangle$
if $\langle q', c, R \rangle \in \delta(q, b_1)$, $m \geq 0$, $n \geq 2$
- ▶ $\langle a_1 \dots a_m, q, b_1 \rangle \vdash_M \langle a_1 \dots a_m c, q', \square \rangle$
if $\langle q', c, R \rangle \in \delta(q, b_1)$, $m \geq 0$

Turing Machines: Reachability of Configurations

Definition (Reachable Configuration)

Configuration c' is **reachable** from configuration c in NTM M ($c \vdash_M^* c'$) if there are configurations c_0, \dots, c_n ($n \geq 0$) where

- ▶ $c_0 = c$,
- ▶ $c_i \vdash_M c_{i+1}$ for all $i \in \{0, \dots, n-1\}$, and
- ▶ $c_n = c'$.

German: c' ist in M von c erreichbar

Turing Machines: Recognized Words

Definition (Recognized Word of a Turing Machine)

NTM $M = \langle Q, \Sigma, \Gamma, \delta, q_0, \square, E \rangle$ recognizes the word $w = a_1 \dots a_n$ iff an accepting configuration (where M is in an end state) is reachable from the start configuration:

$$M \text{ recognizes } w \text{ iff } \langle \varepsilon, q_0, w \rangle \vdash_M^* \langle w_1, q, w_2 \rangle$$

$$\text{for some } q \in E, w_1 \in \Gamma^*, w_2 \in \Gamma^+$$

special case: for $w = \varepsilon$ the start configuration is $\langle \varepsilon, q_0, \square \rangle$
rather than $\langle \varepsilon, q_0, \varepsilon \rangle$

German: M erkennt w , akzeptierende Konfiguration, Startkonfiguration

example: blackboard

Turing Machines: Accepted Language

Definition (Accepted Language of an NTM)

Let M be an NTM with input alphabet Σ .

The **language accepted by M** is defined as

$$\mathcal{L}(M) = \{w \in \Sigma^* \mid M \text{ recognizes } w\}.$$

German: erkannte Sprache

example: blackboard

Exercise

Specify the state diagram of an NTM that accepts language

$$L = \{a^n b^n c^n \mid n \geq 1\}.$$

Feel free to solve this together with your neighbour.

C7.3 Summary

Summary

- ▶ Turing machines only have finitely many states but an **unbounded tape** as “memory”.
- ▶ Alan Turing proposed them as a mathematical model for arbitrary algorithmic computations.
- ▶ In this role, we will revisit them in the parts on computability and complexity theory.