

Theory of Computer Science

C5. Context-free Languages: Normal Form and PDA

Gabriele Röger

University of Basel

April 1, 2019

Theory of Computer Science

April 1, 2019 — C5. Context-free Languages: Normal Form and PDA

C5.1 Context-free Grammars and ε -Rules

C5.2 Chomsky Normal Form

C5.3 Push-Down Automata

C5.4 Summary

Overview

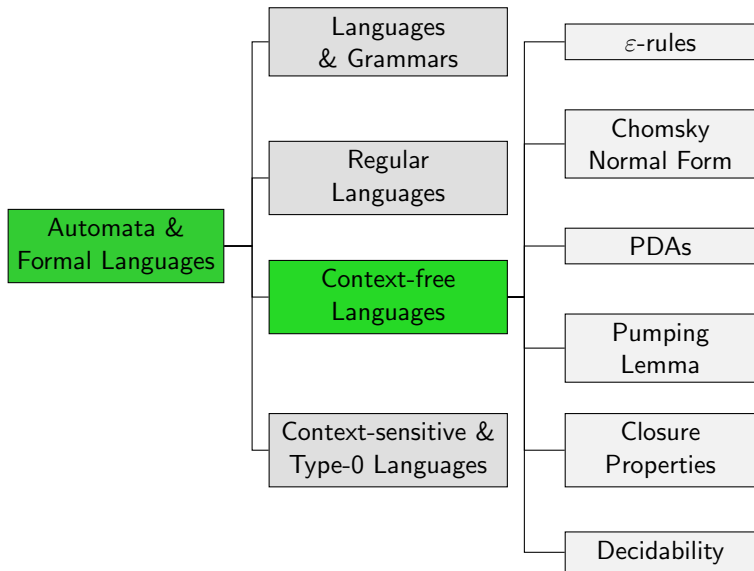

C5.1 Context-free Grammars and ε -Rules

Repetition: Context-free Grammars

Definition (Context-free Grammar)

A **context-free grammar** is a 4-tuple $\langle \Sigma, V, P, S \rangle$ with

- ① Σ finite alphabet of terminal symbols,
- ② V finite set of variables (with $V \cap \Sigma = \emptyset$),
- ③ $P \subseteq (V \times (V \cup \Sigma)^+) \cup \{ \langle S, \varepsilon \rangle \}$ finite set of rules,
- ④ If $S \rightarrow \varepsilon \in P$, then all other rules in $V \times ((V \setminus \{S\}) \cup \Sigma)^+$.
- ⑤ $S \in V$ start variable.

Rule $X \rightarrow \varepsilon$ is only allowed if $X = S$
and S never occurs on a right-hand side.

With regular grammars, this restriction could be lifted.
How about context-free grammars?

Overview

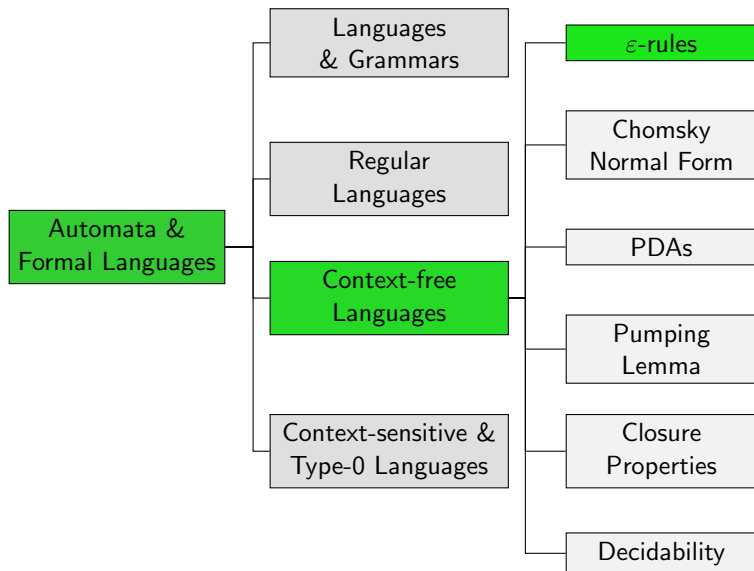

ε -Rules

Theorem

For every grammar G with rules $P \subseteq V \times (V \cup \Sigma)^*$
there is a context-free grammar G' with $\mathcal{L}(G) = \mathcal{L}(G')$.

Proof.

Let $G = \langle \Sigma, V, P, S \rangle$ be a grammar with $P \subseteq V \times (V \cup \Sigma)^*$.

Let $V_\varepsilon = \{A \in V \mid A \Rightarrow^* \varepsilon\}$. We can find this set V_ε by first collecting all variables A with rule $A \rightarrow \varepsilon \in P$ and then successively adding additional variables B if there is a rule $B \rightarrow A_1 A_2 \dots A_k \in P$ and the variables A_i are already in the set for all $1 \leq i \leq k$

ε -Rules

Theorem

For every grammar G with rules $P \subseteq V \times (V \cup \Sigma)^*$
there is a context-free grammar G' with $\mathcal{L}(G) = \mathcal{L}(G')$.

Proof (continued).

Let P' be the rule set that is constructed from P by

- ▶ adding rules that obviate the need for $A \rightarrow \varepsilon$ rules:
for every existing rule $B \rightarrow w$ with $B \in V, w \in (V \cup \Sigma)^+$,
let I_ε be the set of positions where w contains a variable
 $A \in V_\varepsilon$. For every non-empty set $I' \subseteq I_\varepsilon$, add a new rule
 $B \rightarrow w'$, where w' is constructed from w by removing
the variables at all positions in I' .
- ▶ removing all rules of the form $A \rightarrow \varepsilon$ (after the previous step).

...

ε -Rules

Theorem

For every grammar G with rules $P \subseteq V \times (V \cup \Sigma)^*$
there is a context-free grammar G' with $\mathcal{L}(G) = \mathcal{L}(G')$.

Proof (continued).

Then $\mathcal{L}(G) \setminus \{\varepsilon\} = \mathcal{L}(\langle \Sigma, V, P', S \rangle)$ and P' contains no rule $A \rightarrow \varepsilon$. If the start variable S of G is not in V_ε , we are done.

Otherwise, let S' be a new variable and construct P'' from P' by

- 1 replacing all occurrences of S on the right-hand side of rules with S' ,
- 2 adding the rule $S' \rightarrow w$ for every rule $S \rightarrow w$, and
- 3 adding the rule $S \rightarrow \varepsilon$.

Then $\mathcal{L}(G) = \mathcal{L}(\langle \Sigma, V \cup \{S'\}, P'', S \rangle)$. □

C5.2 Chomsky Normal Form

Overview

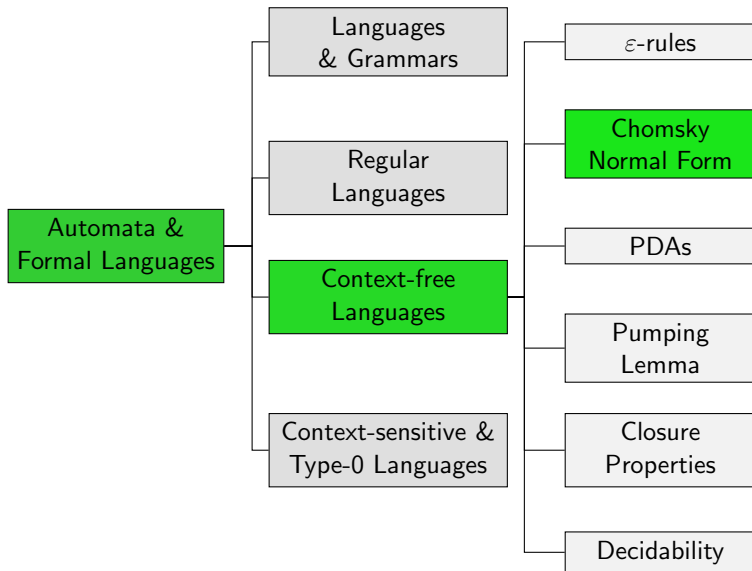

Chomsky Normal Form: Motivation

As in logical formulas (and other kinds of structured objects), **normal forms** for grammars are useful:

- ▶ they show which aspects are critical for defining grammars and which ones are just syntactic sugar
- ▶ they allow proofs and algorithms to be restricted to a limited set of grammars (inputs): those in normal form

Hence we now consider a **normal form** for context-free grammars.

Chomsky Normal Form: Definition

Definition (Chomsky Normal Form)

A context-free grammar G is in **Chomsky normal form (CNF)** if all rules have one of the following three forms:

- ▶ $A \rightarrow BC$ with variables A, B, C , or
- ▶ $A \rightarrow a$ with variable A , terminal symbol a , or
- ▶ $S \rightarrow \varepsilon$ with start variable S .

German: Chomsky-Normalform

in short: rule set $P \subseteq (V \times (VV \cup \Sigma)) \cup \{(S, \varepsilon)\}$

Chomsky Normal Form: Theorem

Theorem

For every context-free grammar G there is a context-free grammar G' in Chomsky normal form with $\mathcal{L}(G) = \mathcal{L}(G')$.

Proof.

The following algorithm converts the rule set of G into CNF:

Step 1: Eliminate rules of the form $A \rightarrow B$ with variables A, B .

If there are sets of variables $\{B_1, \dots, B_k\}$ with rules

$B_1 \rightarrow B_2, B_2 \rightarrow B_3, \dots, B_{k-1} \rightarrow B_k, B_k \rightarrow B_1,$

then replace these variables by a new variable B .

Define a strict total order $<$ on the variables such that $A \rightarrow B \in P$ implies that $A < B$. Iterate from the largest to the smallest variable A and eliminate all rules of the form $A \rightarrow B$ while adding rules $A \rightarrow w$ for every rule $B \rightarrow w$ with $w \in (V \cup \Sigma)^+$

Chomsky Normal Form: Theorem

Theorem

For every context-free grammar G there is a context-free grammar G' in Chomsky normal form with $\mathcal{L}(G) = \mathcal{L}(G')$.

Proof (continued).

Step 2: Eliminate rules with terminal symbols on the right-hand side that do not have the form $A \rightarrow a$.

For every terminal symbol $a \in \Sigma$ add a new variable A_a and the rule $A_a \rightarrow a$.

Replace all terminal symbols in all rules that do not have the form $A \rightarrow a$ with the corresponding newly added variables. . . .

Chomsky Normal Form: Theorem

Theorem

For every context-free grammar G there is a context-free grammar G' in Chomsky normal form with $\mathcal{L}(G) = \mathcal{L}(G')$.

Proof (continued).

Step 3: Eliminate rules of the form $A \rightarrow B_1 B_2 \dots B_k$ with $k > 2$

For every rule of the form $A \rightarrow B_1 B_2 \dots B_k$ with $k > 2$, add new variables C_2, \dots, C_{k-1} and replace the rule with

$$\begin{aligned} A &\rightarrow B_1 C_2 \\ C_2 &\rightarrow B_2 C_3 \\ &\vdots \\ C_{k-1} &\rightarrow B_{k-1} B_k \end{aligned}$$



Chomsky Normal Form: Length of Derivations

Observation

Let G be a grammar in Chomsky normal form,
and let $w \in \mathcal{L}(G)$ be a non-empty word generated by G .
Then all derivations of w have exactly $2|w| - 1$ derivation steps.

Proof.

\rightsquigarrow Exercises



C5.3 Push-Down Automata

Overview

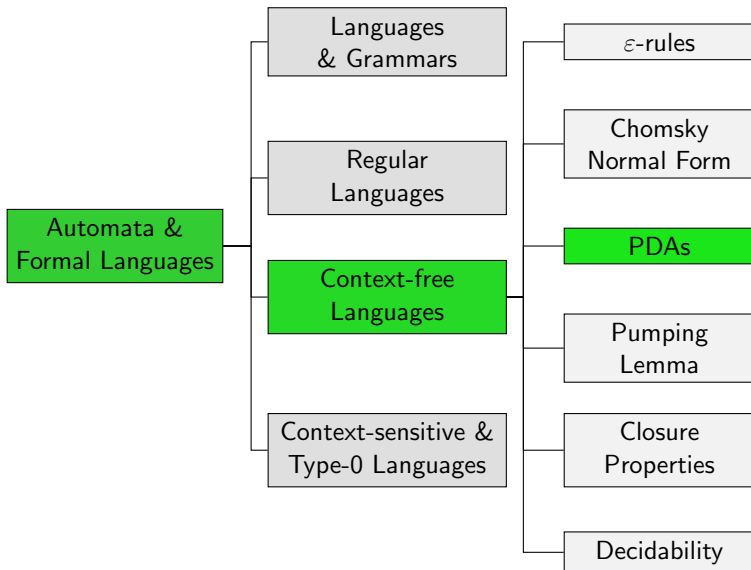

Limitations of Finite Automata

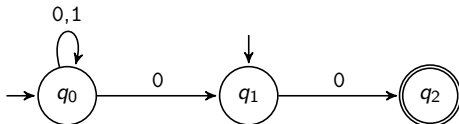

- ▶ Language L is regular.
 \iff There is a finite automaton that accepts L .
- ▶ What information can a finite automaton “store” about the already read part of the word?
- ▶ Infinite memory would be required for
 $L = \{x_1x_2 \dots x_nx_n \dots x_2x_1 \mid n > 0, x_i \in \{a, b\}\}$.
- ▶ therefore: extension of the automata model with memory

Stack

A **stack** is a data structure following the **last-in-first-out (LIFO)** principle supporting the following operations:

- ▶ **push**: puts an object on top of the stack
- ▶ **pop**: removes the object at the top of the stack
- ▶ **peek**: returns the top object without removing it

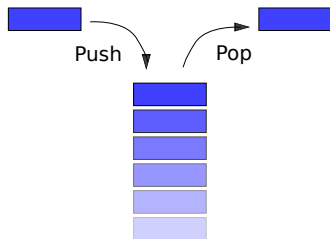

German: Keller, Stapel

Push-down Automata: Visually

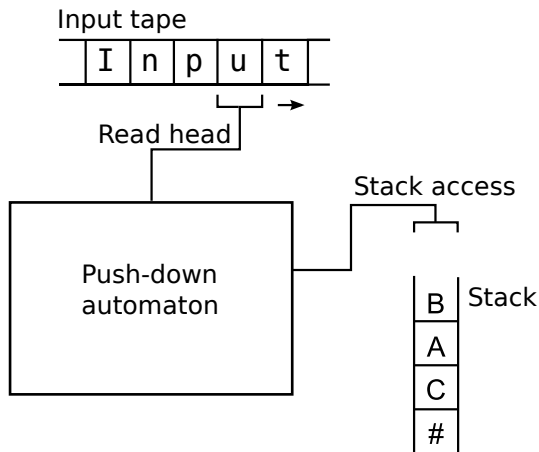

German: Kellerautomat, Eingabeband, Lesekopf, Kellerzugriff

Push-down Automata: Definition

Definition (Push-down Automaton)

A **push-down automaton (PDA)** is a 6-tuple $M = \langle Q, \Sigma, \Gamma, \delta, q_0, \# \rangle$ with

- ▶ Q finite set of states
- ▶ Σ the input alphabet
- ▶ Γ the stack alphabet
- ▶ $\delta : Q \times (\Sigma \cup \{\varepsilon\}) \times \Gamma \rightarrow \mathcal{P}_f(Q \times \Gamma^*)$ the transition function (where \mathcal{P}_f is the set of all **finite** subsets)
- ▶ $q_0 \in Q$ the start state
- ▶ $\# \in \Gamma$ the bottommost stack symbol

German: Kellerautomat, Eingabealphabet, Kelleralphabet, Überföhrungsfunktion

Push-down Automata: Transition Function

Let $M = \langle Q, \Sigma, \Gamma, \delta, q_0, \# \rangle$ be a push-down automaton.

What is the Intuitive Meaning of the Transition Function δ ?

- ▶ $\langle q', B_1 \dots B_k \rangle \in \delta(q, a, A)$: If M is in state q , reads symbol a and has A as the topmost stack symbol, then M **can** transition to q' in the next step while replacing A with $B_1 \dots B_k$ (afterwards B_1 is the topmost stack symbol)

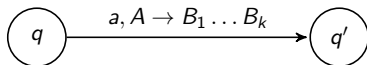

- ▶ special case $a = \varepsilon$ is allowed (spontaneous transition)

Push-down Automata: Example

$a, A \rightarrow AA$
 $a, B \rightarrow AB$
 $a, \# \rightarrow A\#$
 $b, A \rightarrow BA$
 $b, B \rightarrow BB$
 $b, \# \rightarrow B\#$

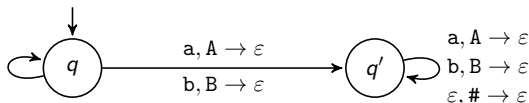

$M = \langle \{q, q'\}, \{a, b\}, \{A, B, \#\}, \delta, q, \# \rangle$ with

$\delta(q, a, A) = \{\langle q, AA \rangle, \langle q', \varepsilon \rangle\}$	$\delta(q, b, A) = \{\langle q, BA \rangle\}$	$\delta(q, \varepsilon, A) = \emptyset$
$\delta(q, a, B) = \{\langle q, AB \rangle\}$	$\delta(q, b, B) = \{\langle q, BB \rangle, \langle q', \varepsilon \rangle\}$	$\delta(q, \varepsilon, B) = \emptyset$
$\delta(q, a, \#) = \{\langle q, A\# \rangle\}$	$\delta(q, b, \#) = \{\langle q, B\# \rangle\}$	$\delta(q, \varepsilon, \#) = \emptyset$
$\delta(q', a, A) = \{\langle q', \varepsilon \rangle\}$	$\delta(q', b, A) = \emptyset$	$\delta(q', \varepsilon, A) = \emptyset$
$\delta(q', a, B) = \emptyset$	$\delta(q', b, B) = \{\langle q', \varepsilon \rangle\}$	$\delta(q', \varepsilon, B) = \emptyset$
$\delta(q', a, \#) = \emptyset$	$\delta(q', b, \#) = \emptyset$	$\delta(q', \varepsilon, \#) = \{\langle q', \varepsilon \rangle\}$

Push-down Automata: Configuration

Definition (Configuration of a Push-down Automaton)

A **configuration** of a push-down automaton $M = \langle Q, \Sigma, \Gamma, \delta, q_0, \# \rangle$ is given by a triple $c \in Q \times \Sigma^* \times \Gamma^*$.

German: Konfiguration

Example

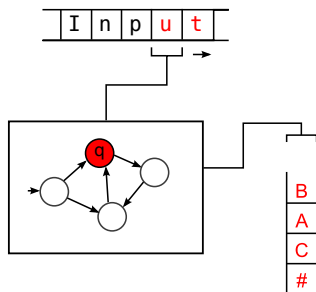

Configuration
 $\langle q, ut, BAC\# \rangle$.

Push-down Automata: Steps

Definition (Transition/Step of a Push-down Automaton)

We write $c \vdash_M c'$ if a push-down automaton $M = \langle Q, \Sigma, \Gamma, \delta, q_0, \# \rangle$ can transition from configuration c to configuration c' in one step. Exactly the following transitions are possible:

$$\langle q, a_1 \dots a_n, A_1 \dots A_m \rangle \vdash_M \begin{cases} \langle q', a_2 \dots a_n, B_1 \dots B_k A_2 \dots A_m \rangle \\ \quad \text{if } \langle q', B_1 \dots B_k \rangle \in \delta(q, a_1, A_1) \\ \\ \langle q', a_1 a_2 \dots a_n, B_1 \dots B_k A_2 \dots A_m \rangle \\ \quad \text{if } \langle q', B_1 \dots B_k \rangle \in \delta(q, \varepsilon, A_1) \end{cases}$$

German: Übergang

If M is clear from context, we only write $c \vdash c'$.

Push-down Automata: Reachability of Configurations

Definition (Reachable Configuration)

Configuration c' is **reachable** from configuration c in PDA M ($c \vdash_M^* c'$) if there are configurations c_0, \dots, c_n ($n \geq 0$) where

- ▶ $c_0 = c$,
- ▶ $c_i \vdash_M c_{i+1}$ for all $i \in \{0, \dots, n-1\}$, and
- ▶ $c_n = c'$.

German: c' ist in M von c erreichbar

Push-down Automata: Recognized Words

Definition (Recognized Word of a Push-down Automaton)

PDA $M = \langle Q, \Sigma, \Gamma, \delta, q_0, \# \rangle$ **recognizes the word** $w = a_1 \dots a_n$ iff the configuration $\langle q, \varepsilon, \varepsilon \rangle$ (**word processed** and **stack empty**) for some $q \in Q$ is reachable from the **start configuration** $\langle q_0, w, \# \rangle$.

M recognizes w iff $\langle q_0, w, \# \rangle \vdash_M^* \langle q, \varepsilon, \varepsilon \rangle$ for some $q \in Q$.

German: M erkennt w , Startkonfiguration

Push-down Automata: Recognized Word Example

$a, A \rightarrow AA$
 $a, B \rightarrow AB$
 $a, \# \rightarrow A\#$
 $b, A \rightarrow BA$
 $b, B \rightarrow BB$
 $b, \# \rightarrow B\#$

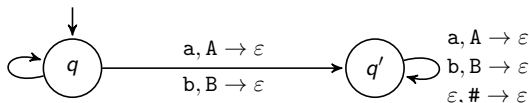

example: this PDA recognizes $bbabbabb \rightsquigarrow$ **blackboard**

Push-down Automata: Accepted Language

Definition (Accepted Language of a Push-down Automaton)

Let M be a push-down automaton with input alphabet Σ .

The **language accepted by M** is defined as

$$\mathcal{L}(M) = \{w \in \Sigma^* \mid M \text{ recognizes } w\}.$$

example: blackboard

PDA's Accept Exactly the Context-free Languages

Theorem

A language L is context-free if and only if L is accepted by a push-down automaton.

C5.4 Summary

Summary

- ▶ Every context-free language has a grammar in **Chomsky normal form**. All rules have form
 - ▶ $A \rightarrow BC$ with variables A, B, C , or
 - ▶ $A \rightarrow a$ with variable A , terminal symbol a , or
 - ▶ $S \rightarrow \varepsilon$ with start variable S .
- ▶ **Push-down automata** (PDAs) extend NFAs with memory.
- ▶ PDAs **accept** not with end states but with an **empty stack**.
- ▶ The **languages accepted by PDAs** are exactly the **context-free languages**.